



www.lrtcity.com/royal-sentul-park



“

In the symphony of commerce, a healthy environment is the conductor that orchestrates sustainable success.

”

Ruko Kawasan

LRT City Sentul





Welcome.

Selamat datang di kawasan yang menawarkan ruko dengan desain yang eksklusif dan lokasi yang strategis untuk memulai usaha. Dengan desain yang menggabungkan kemewahan dan fungsionalitas, kami memberikan solusi ideal bagi para pebisnis yang ingin mengambil langkah pertama dalam mewujudkan impian mereka. Jangan lewatkan kesempatan ini untuk memiliki ruang usaha yang sempurna di tempat yang tepat.

serenity



—— Healthy Environment

Terletak di kawasan yang rimbun dengan pepohonan, lingkungan yang nyaman dan sejuk, memberikan suasana yang ideal untuk mewujudkan kreativitas dan produktivitas.

Map Location

LRT City Sentul
Kawasan Royal Sentul Park Apartement

Exit Tol Sentul Sirkuit, Km.33 - Jagorawi
Jl. Sentul Raya, Kadumanggu,
Babakan Madang - Bogor

Access

- Via Tol Sentul IPSC
2 Menit
- Via Tol Sentul Selatan
5 Menit
- Via Jalan Raya Bogor
15 Menit

LRT CITY
SENTUL

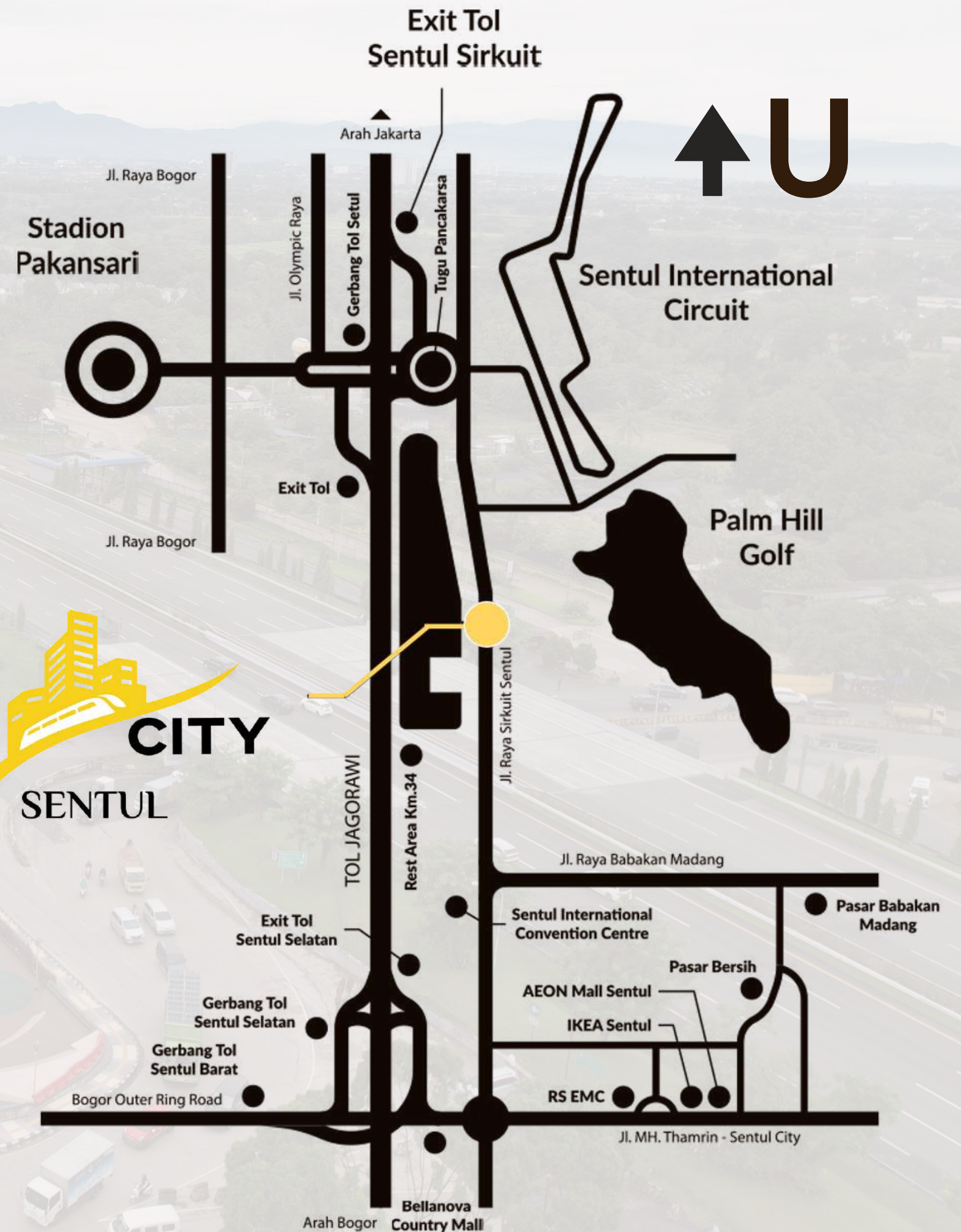

A photograph of a modern building facade. The building features a mix of materials: dark brown brick on the left and right sides, and large glass panels in the center. The glass reflects the surrounding environment, including trees and other buildings. The sky is overcast. The text 'SPECIFICATION' is overlaid in the center, with a horizontal line above and below it. Below that, the text 'Beneficial Partnership need beneficial specification' is overlaid.

SPECIFICATION

Beneficial Partnership need beneficial specification

LAYOUT





Lt.1



Lt.2



Lt.3

RUKO

A



LANTAI

Homogeneous Tile

DINDING

Bata Ringan - Plester

SANITARI

Toto

PLAFOND

Exposed

KUSEN

Alumunium



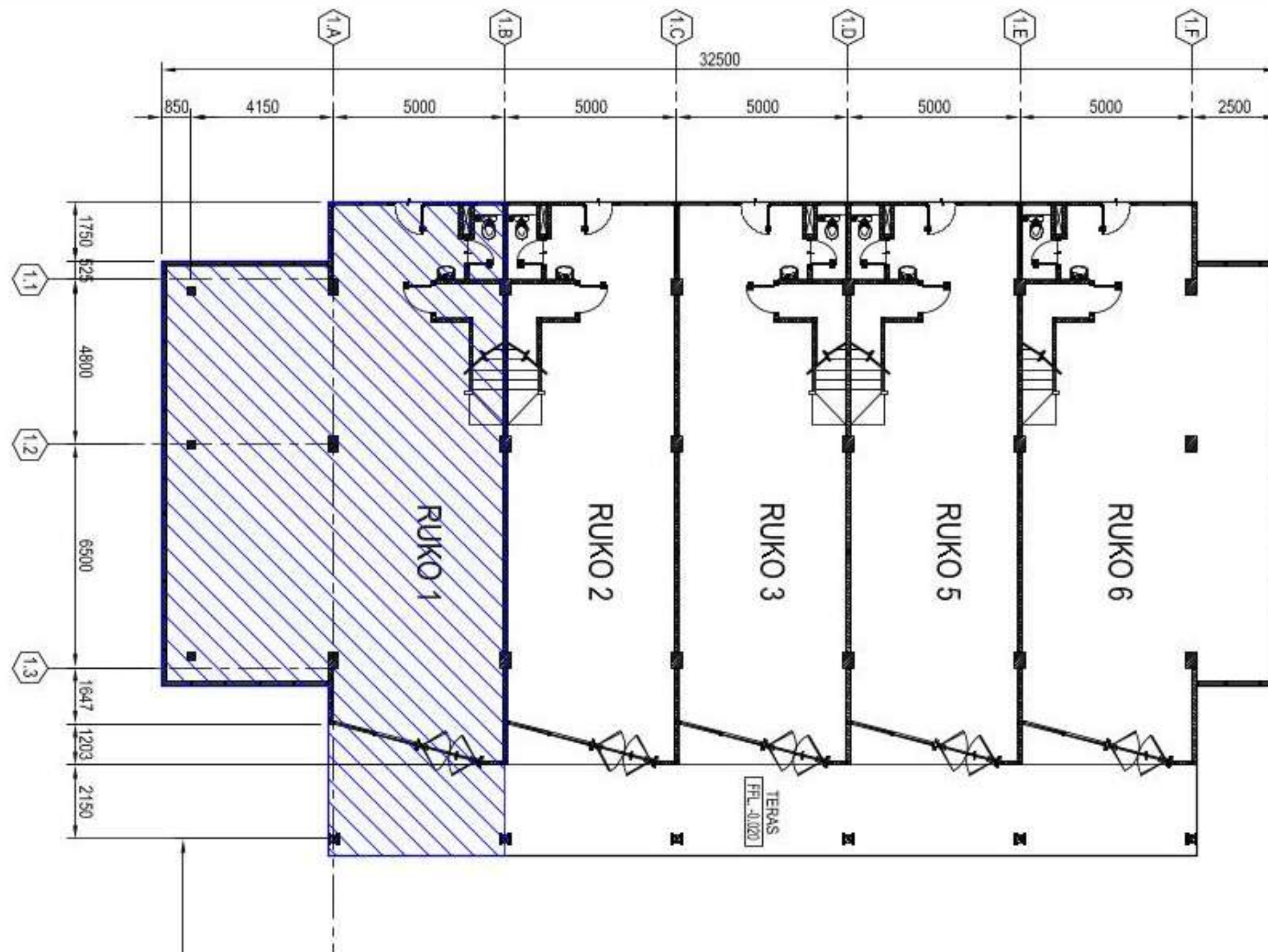

RUKO A

LUAS BANGUNAN • 230 m² • 305 m²

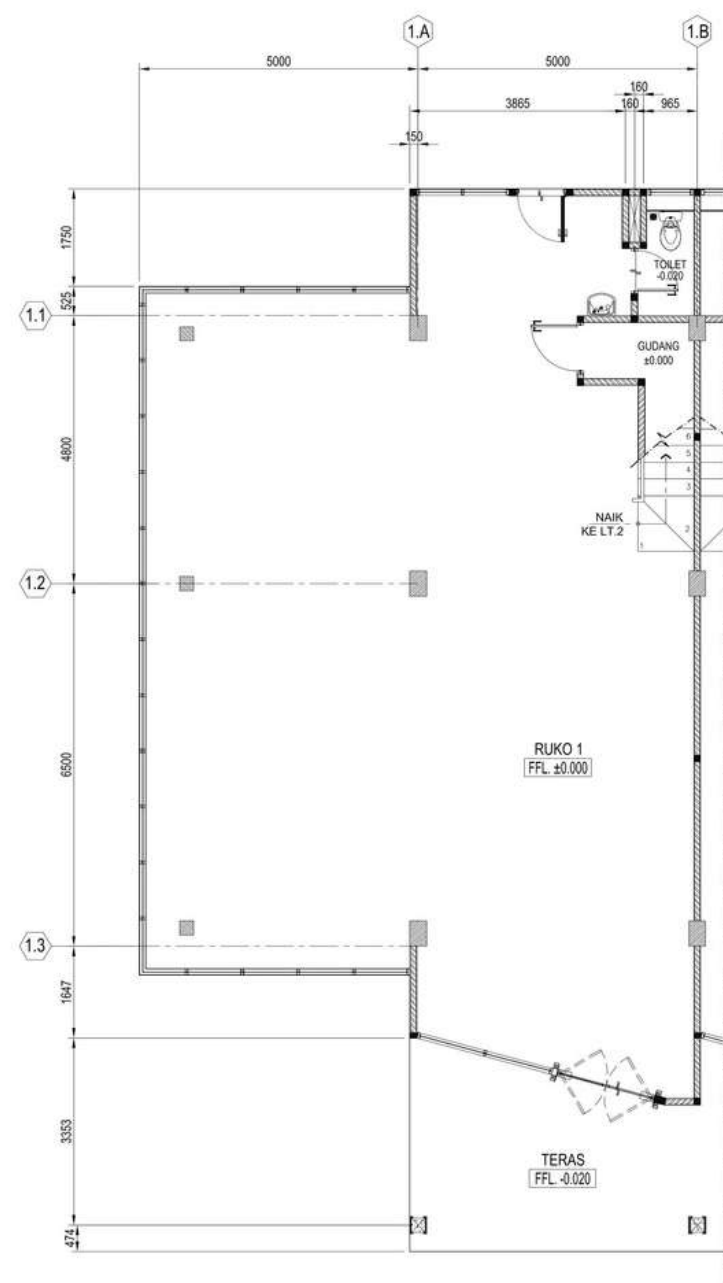

LT.1

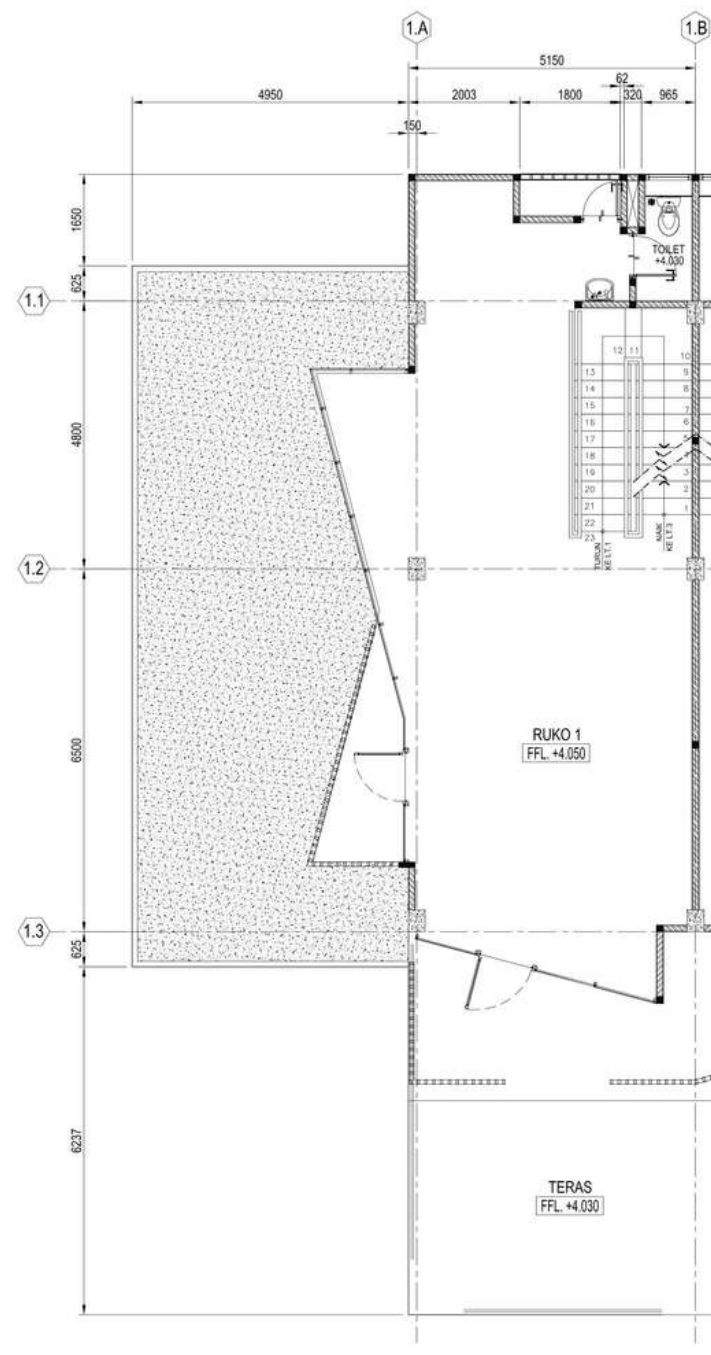

LT.2

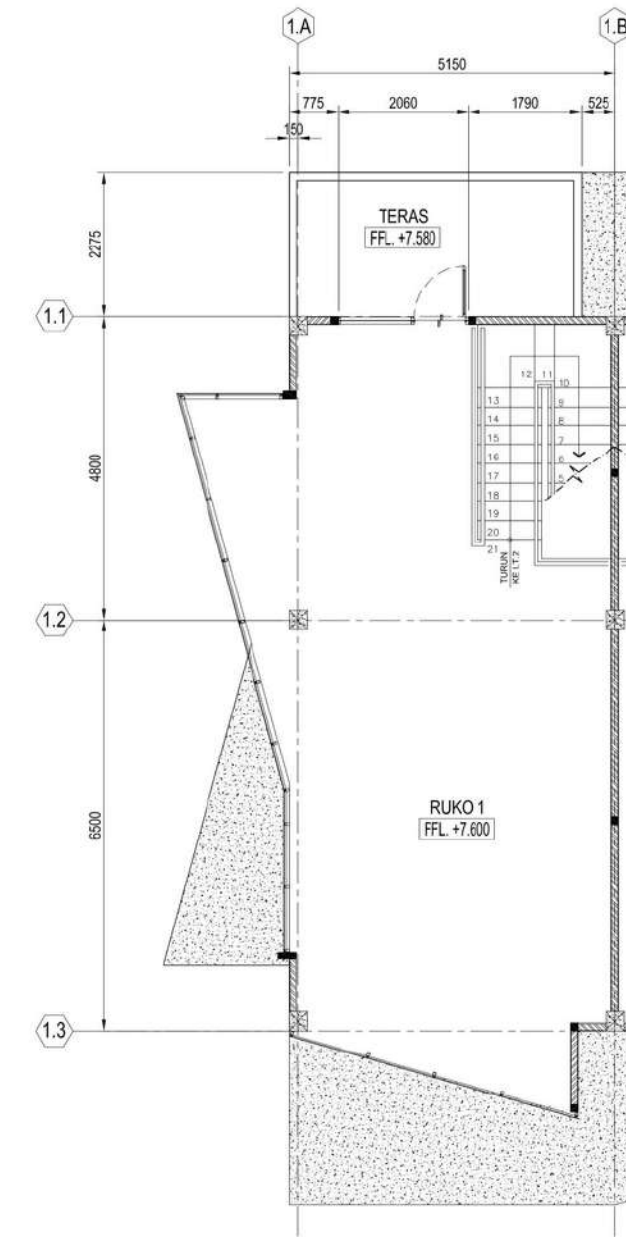

LT.3

RUKO A

LUAS BANGUNAN • 230 m² • 305 m²

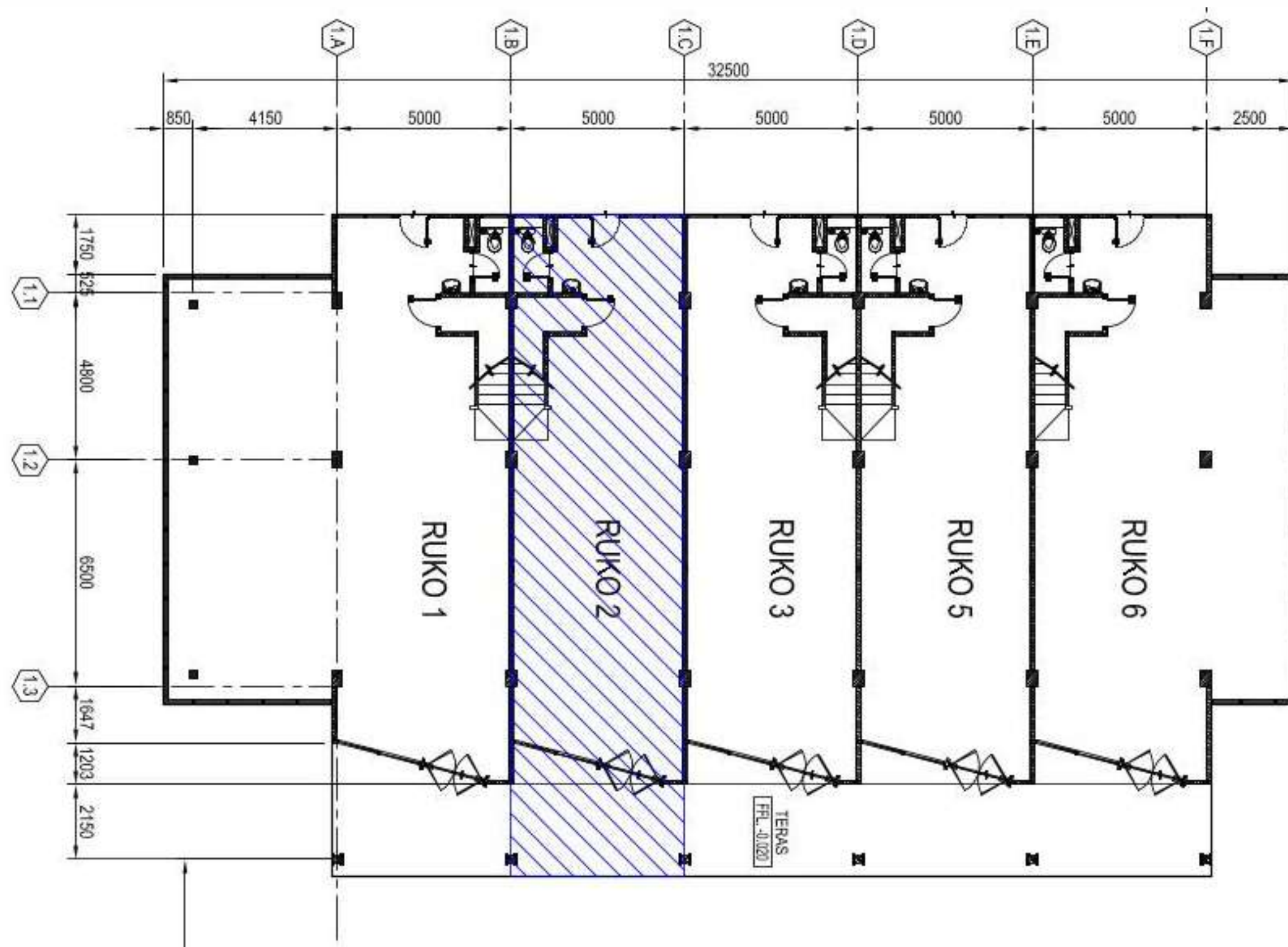

RUKO A

LUAS BANGUNAN

• 230 m²

• 305 m²

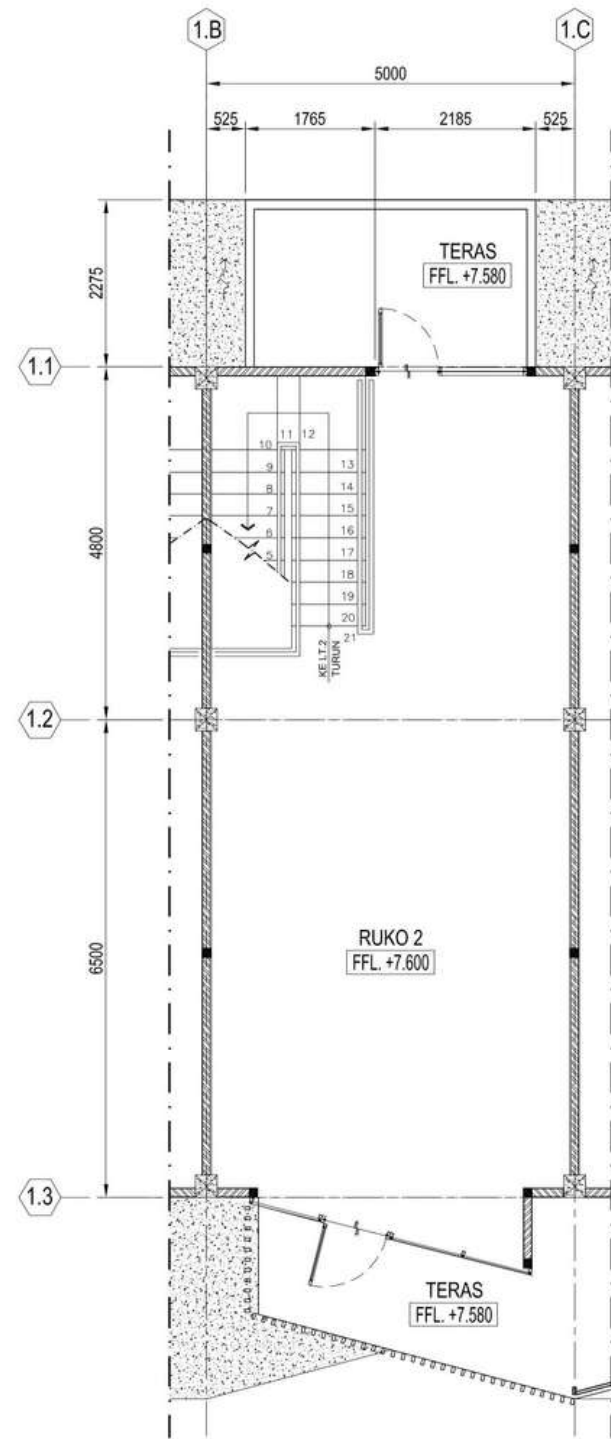

LT.1

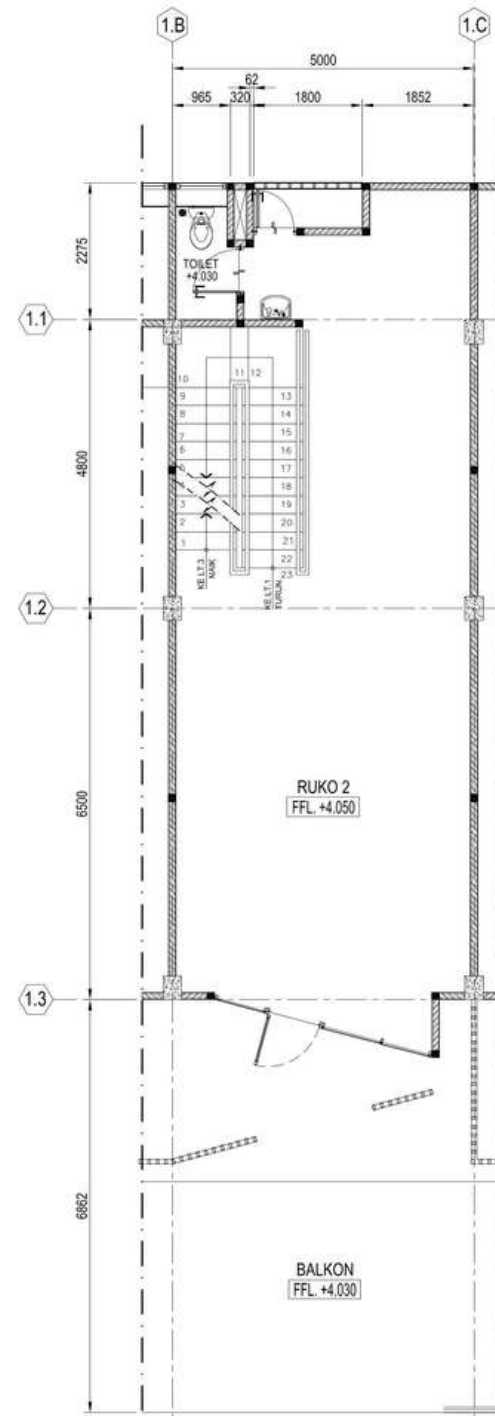

LT.2

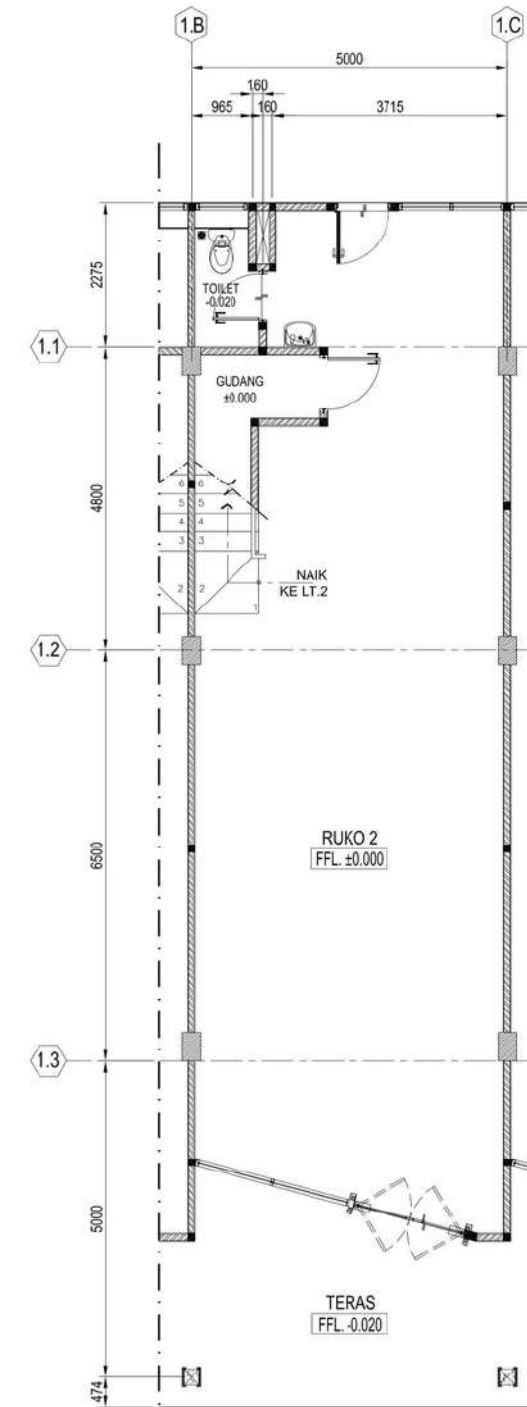

LT.3

RUKO A

LUAS BANGUNAN • 230 m²

• 305 m²



RUKO

B

LANTAI

Homogeneous Tile

DINDING

Bata Ringan - Plester

SANITARI

Toto

PLAFOND

Exposed

KUSEN

Alumunium

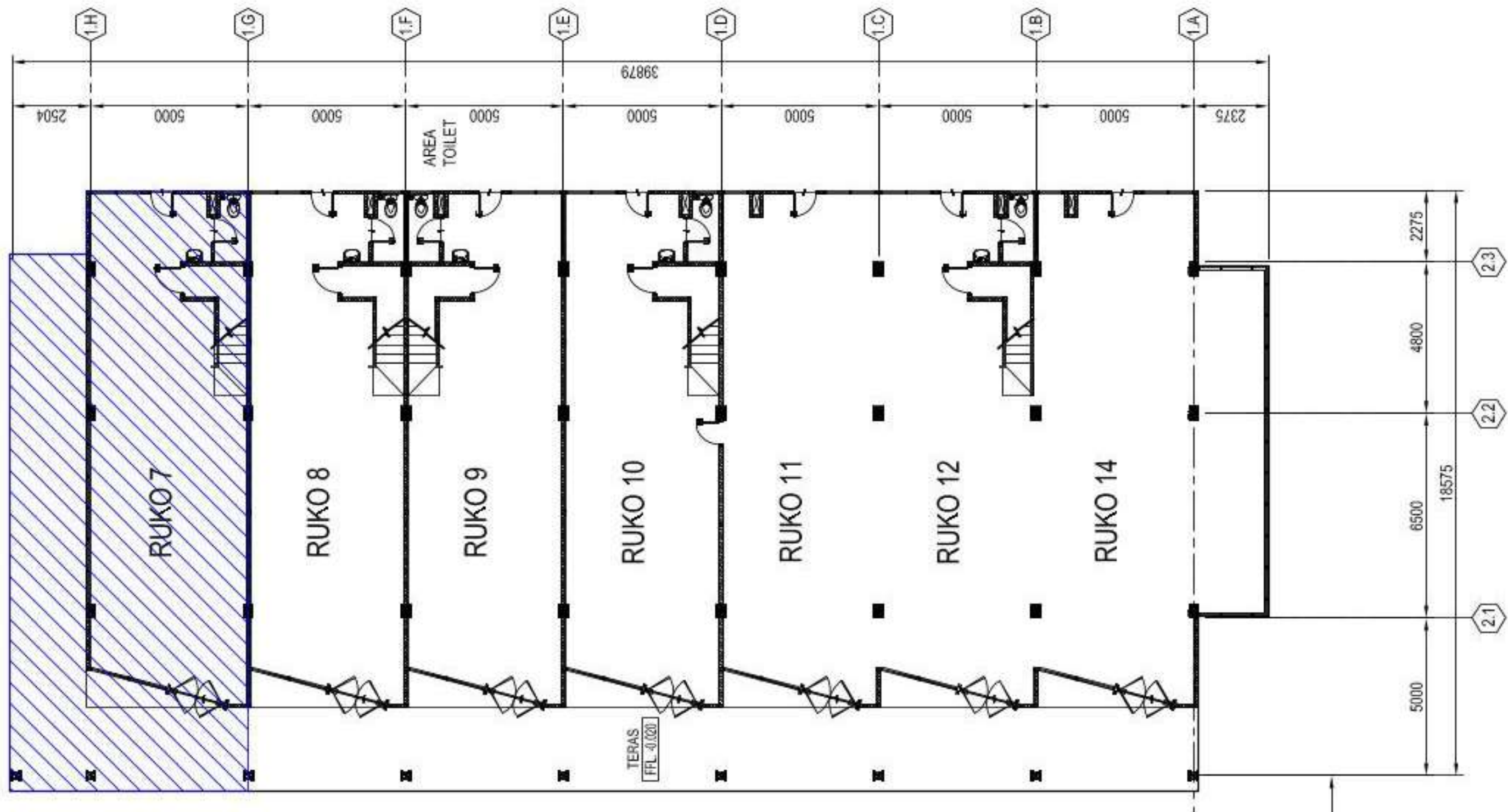

RUKO B

LUAS BANGUNAN

• 235 m²

• 290 m²

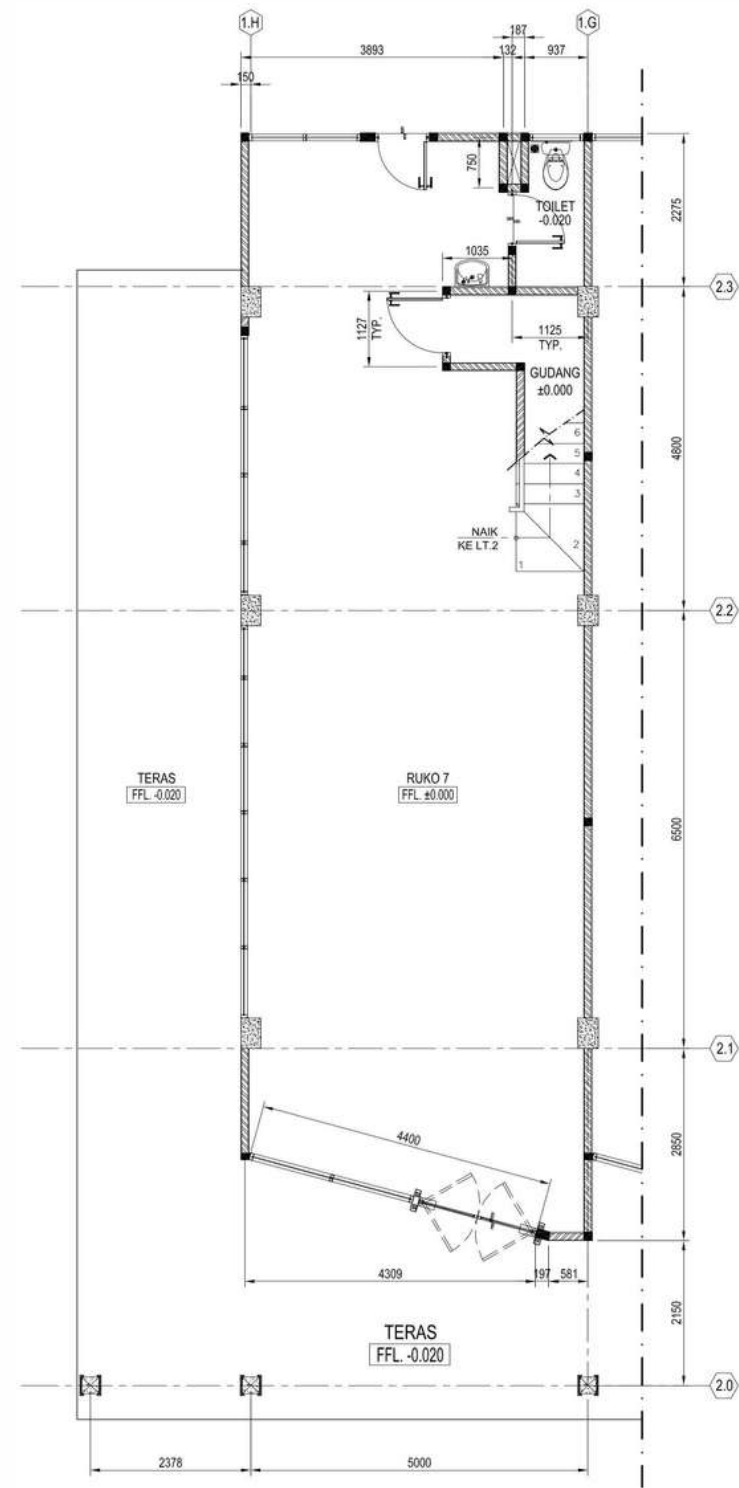

LT.1

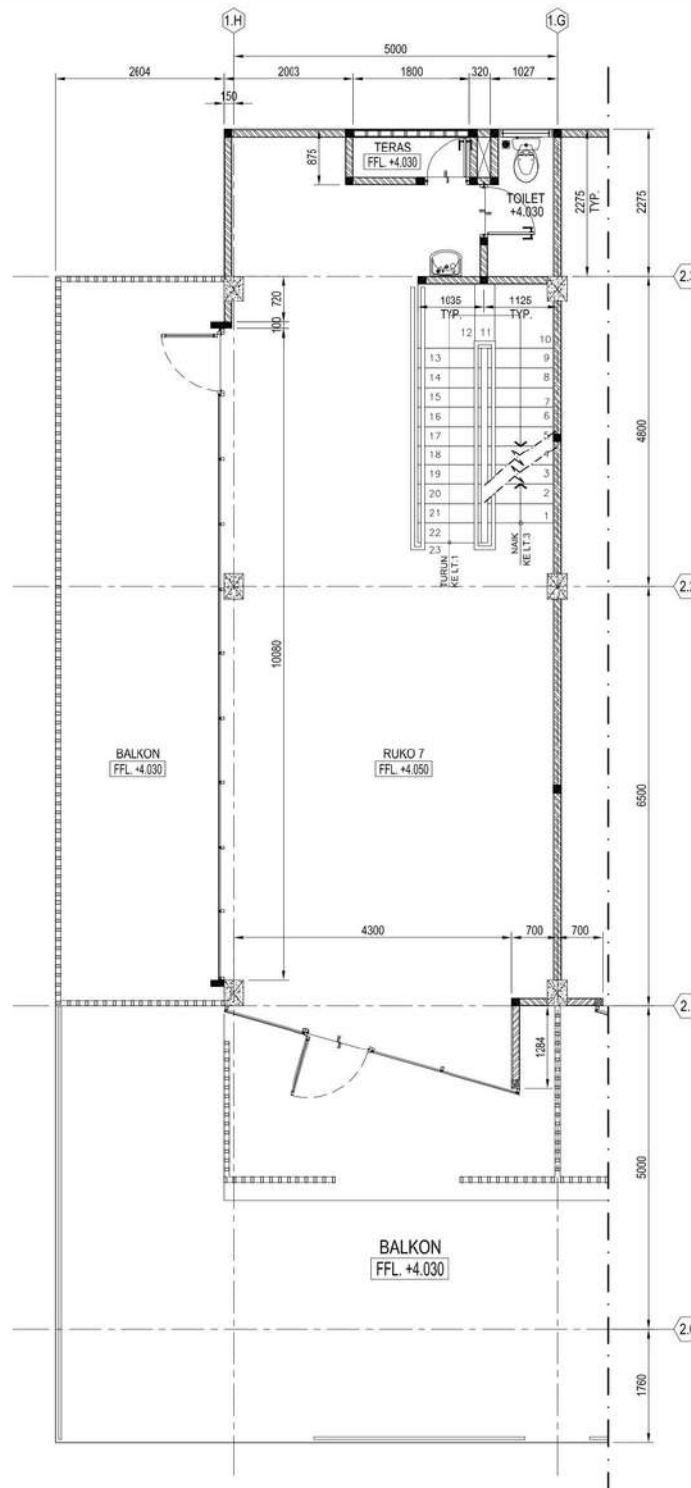

LT.2

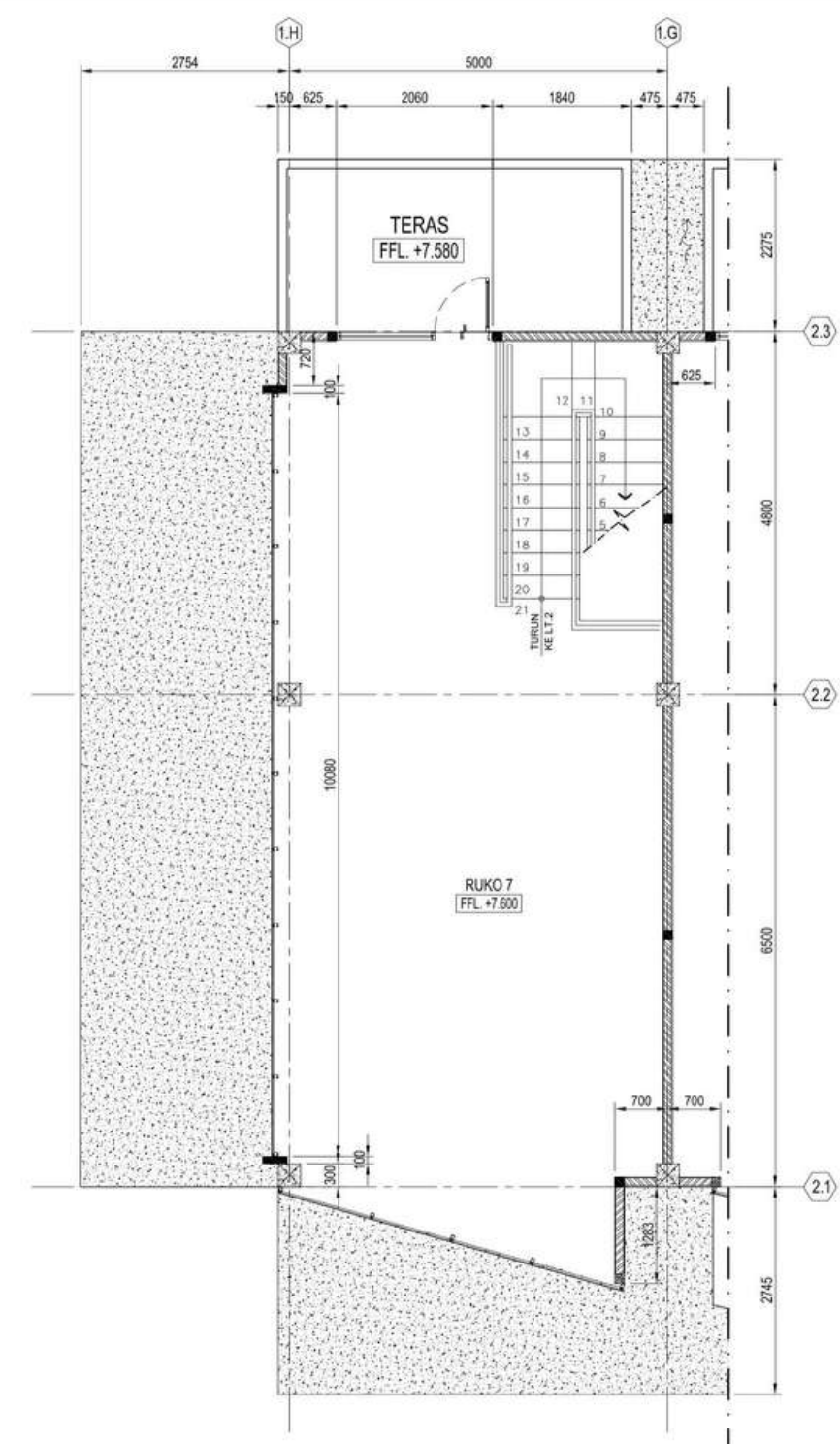

LT.3

RUKO B

LUAS BANGUNAN

• 235 m²

• 290 m²

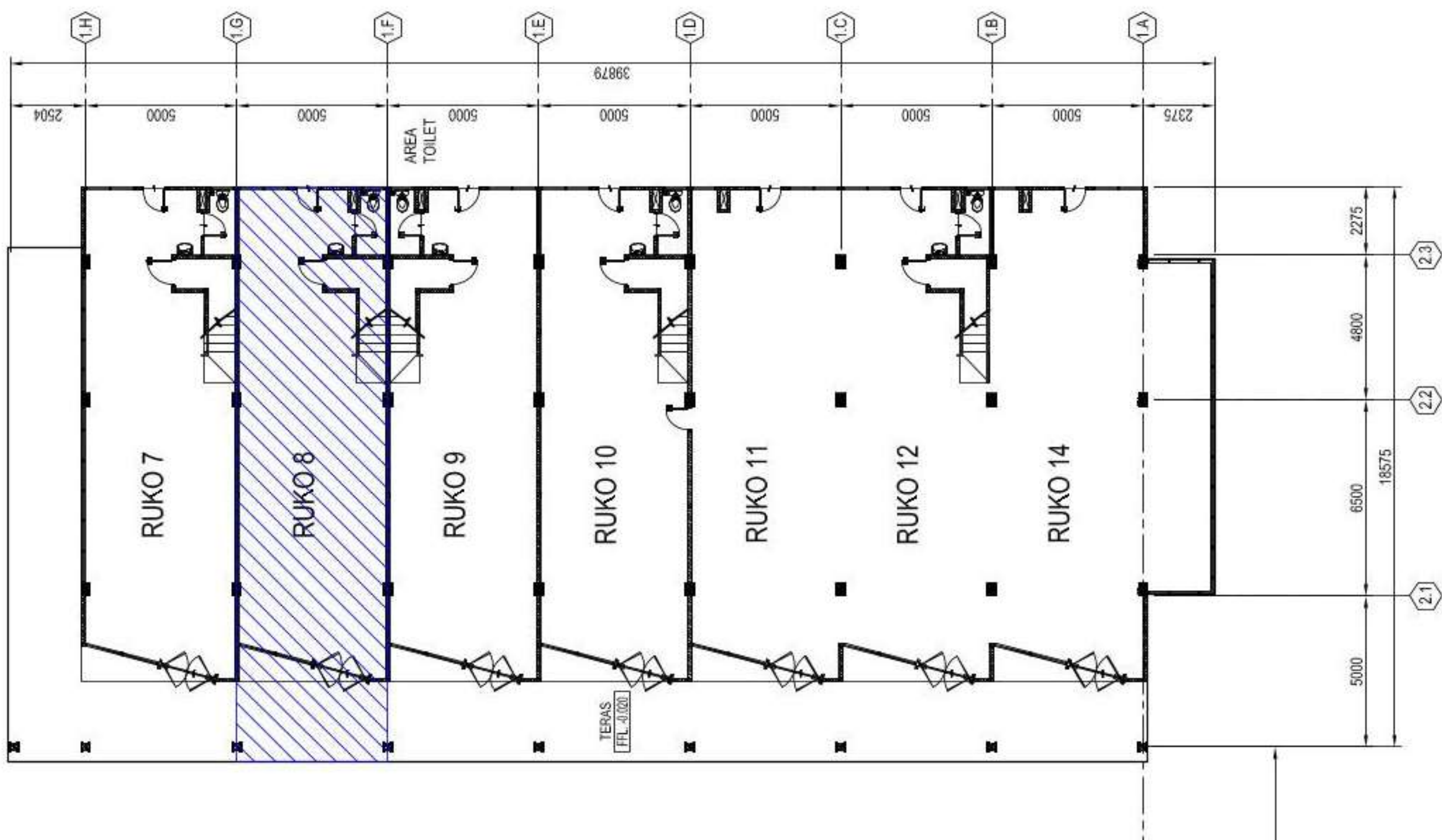

RUKO B

LUAS BANGUNAN

• 235 m²

• 290 m²

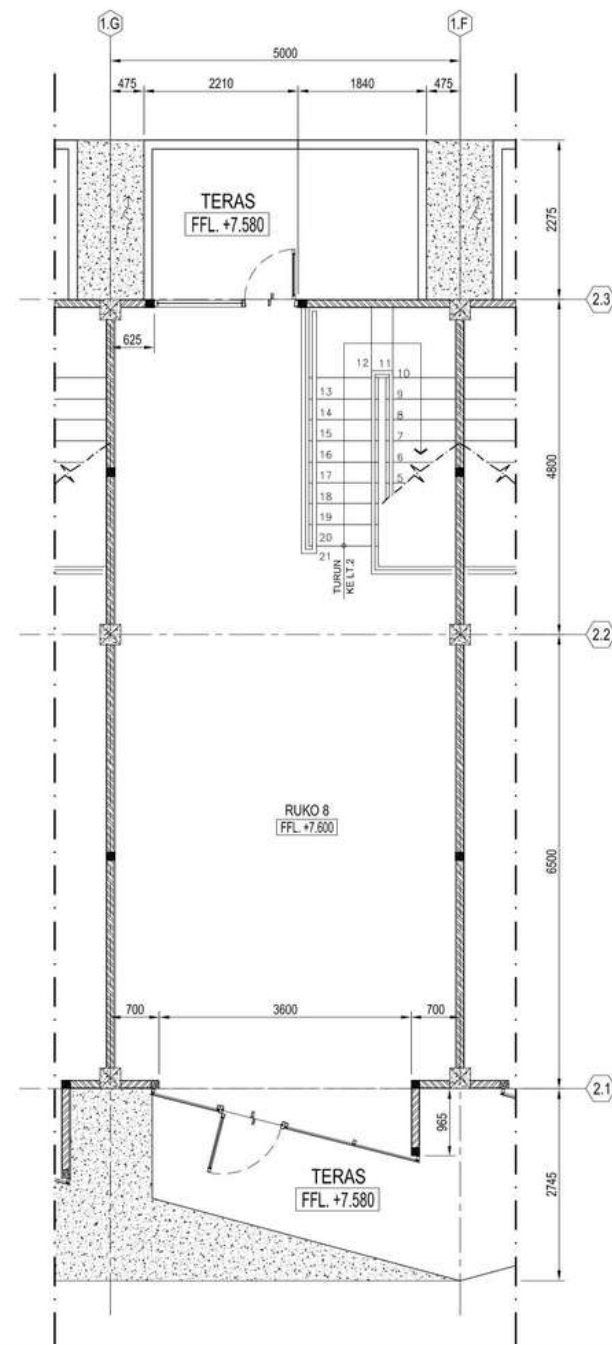

LT.1

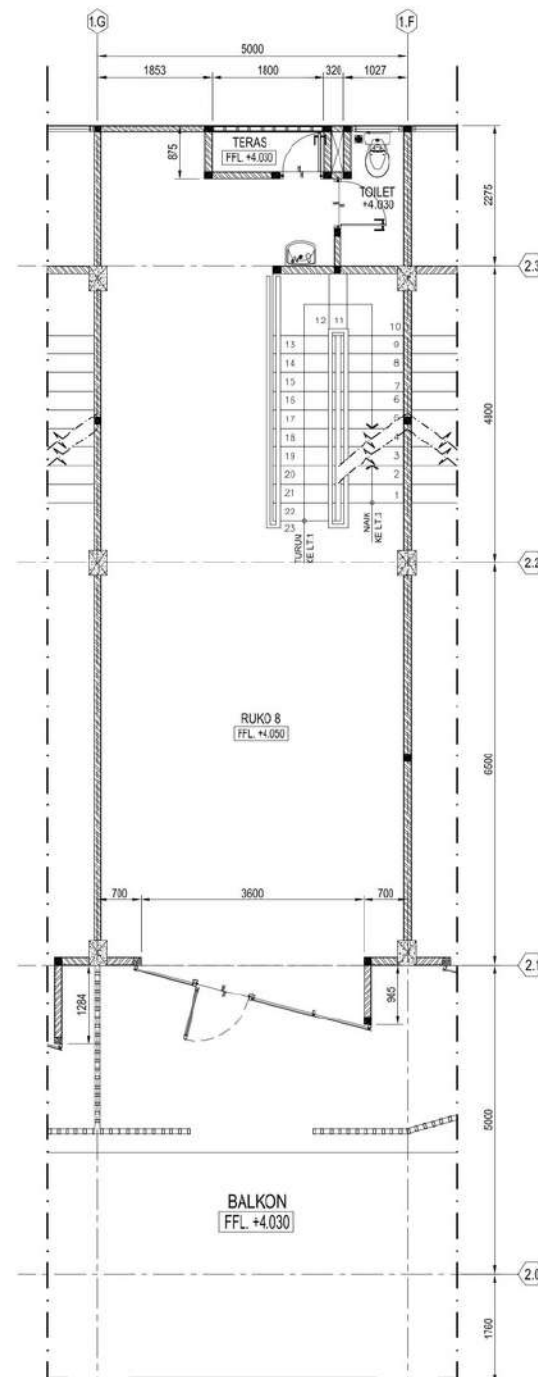

LT.2

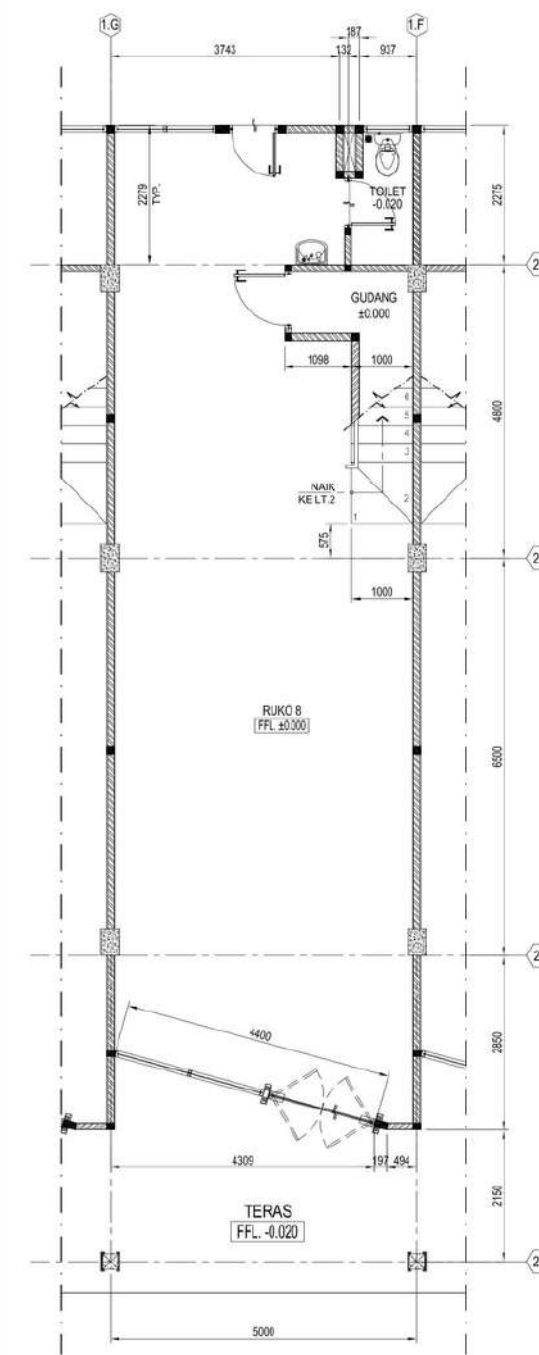

LT.3

RUKO B

LUAS BANGUNAN • 235 m²

• 290 m²

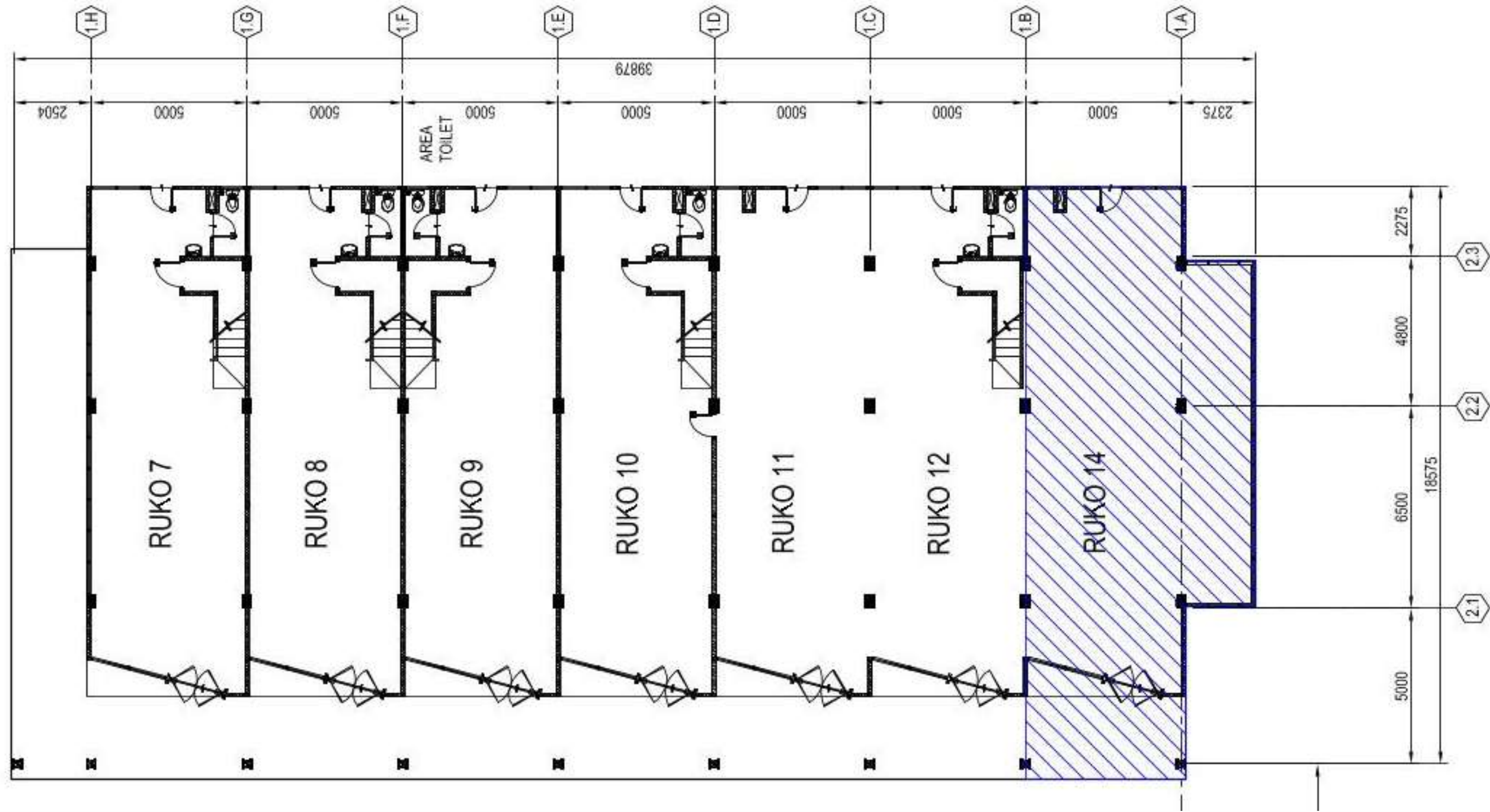

RUKO B

LUAS BANGUNAN

• 235 m²

• 290 m²

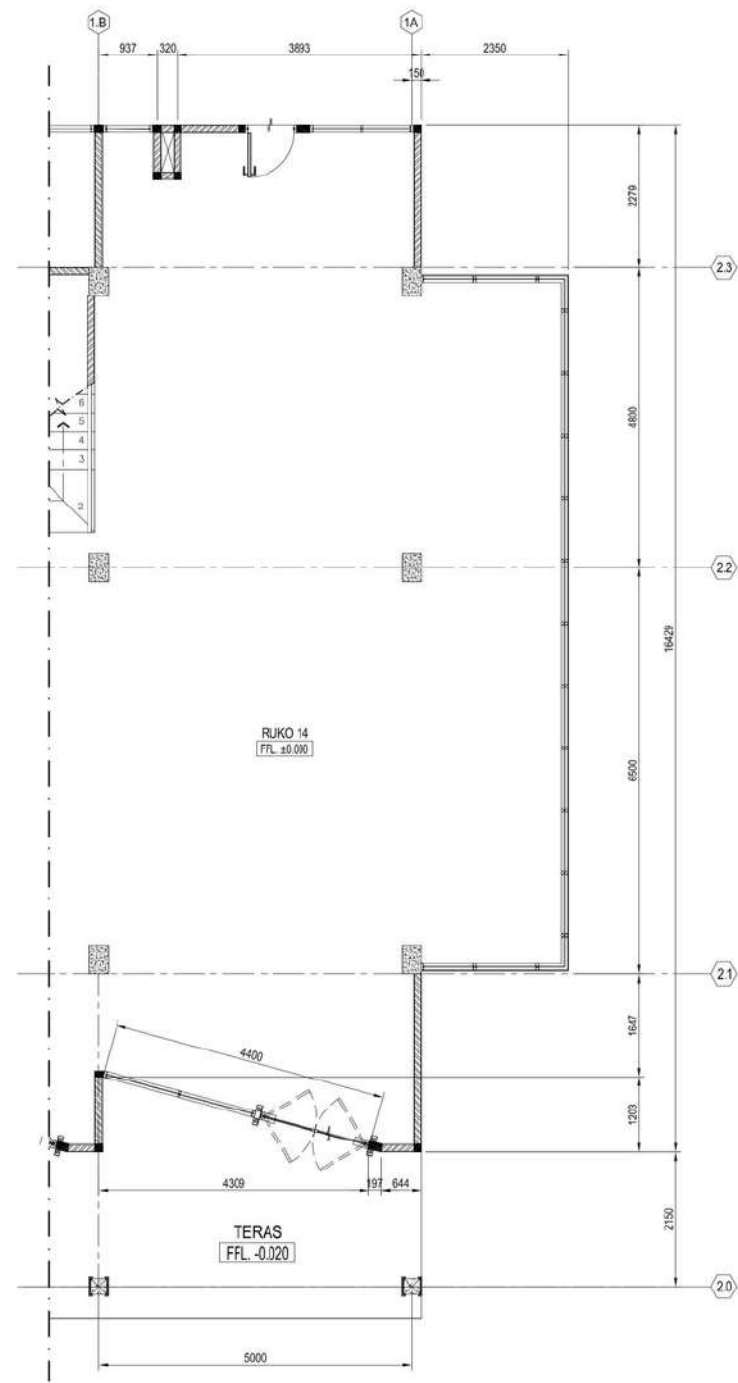

LT.1

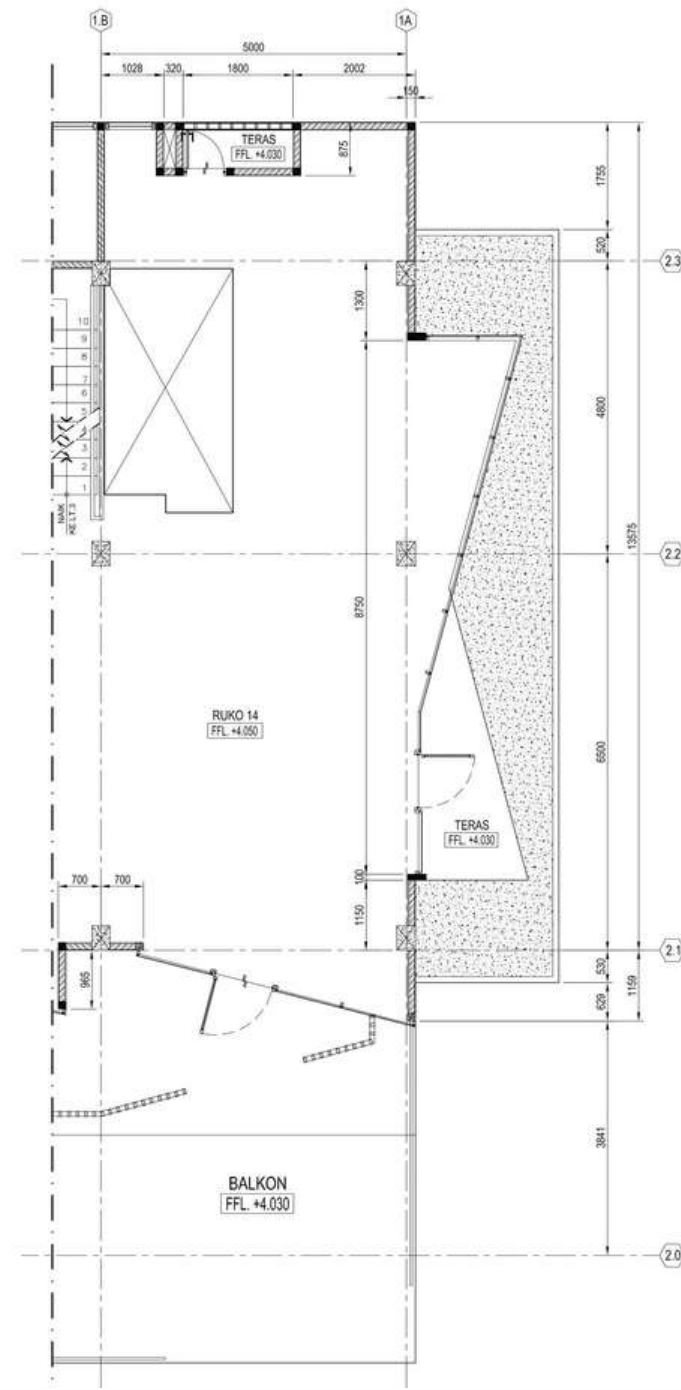

LT.2

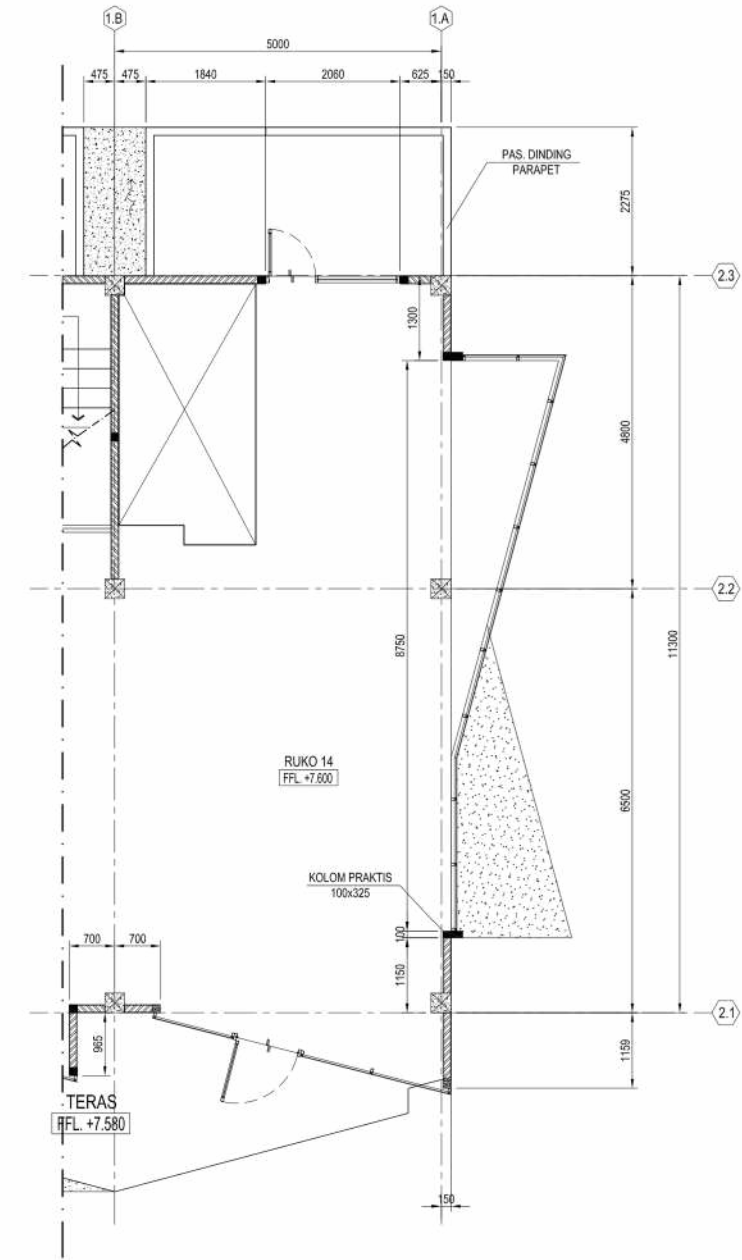

LT.3

RUKO B

LUAS BANGUNAN

• 235 m²

• 290 m²



RUKO

C

LANTAI

Homogeneous Tile

DINDING

Bata Ringan - Plester

SANITARI

Toto

PLAFOND

Exposed

KUSEN

Alumunium

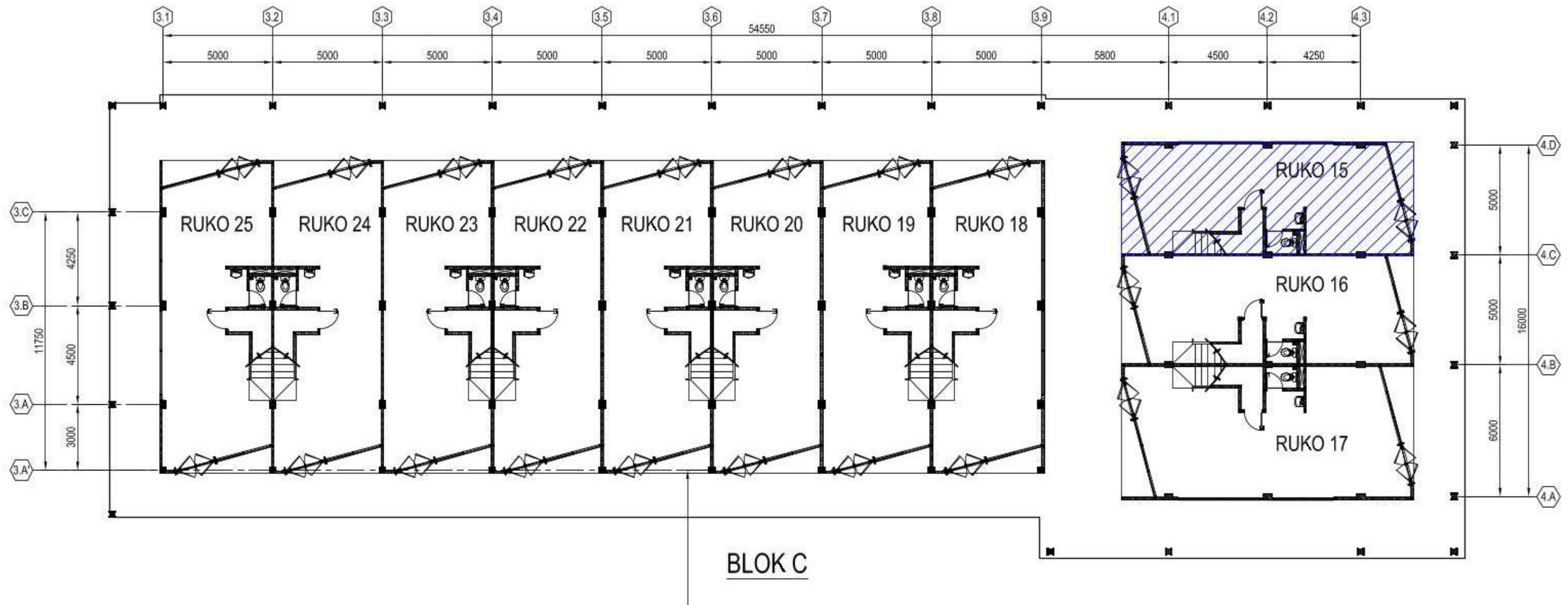

RUKO C

LUAS BANGUNAN

• 190m²

• 234 m²

• 255 m²

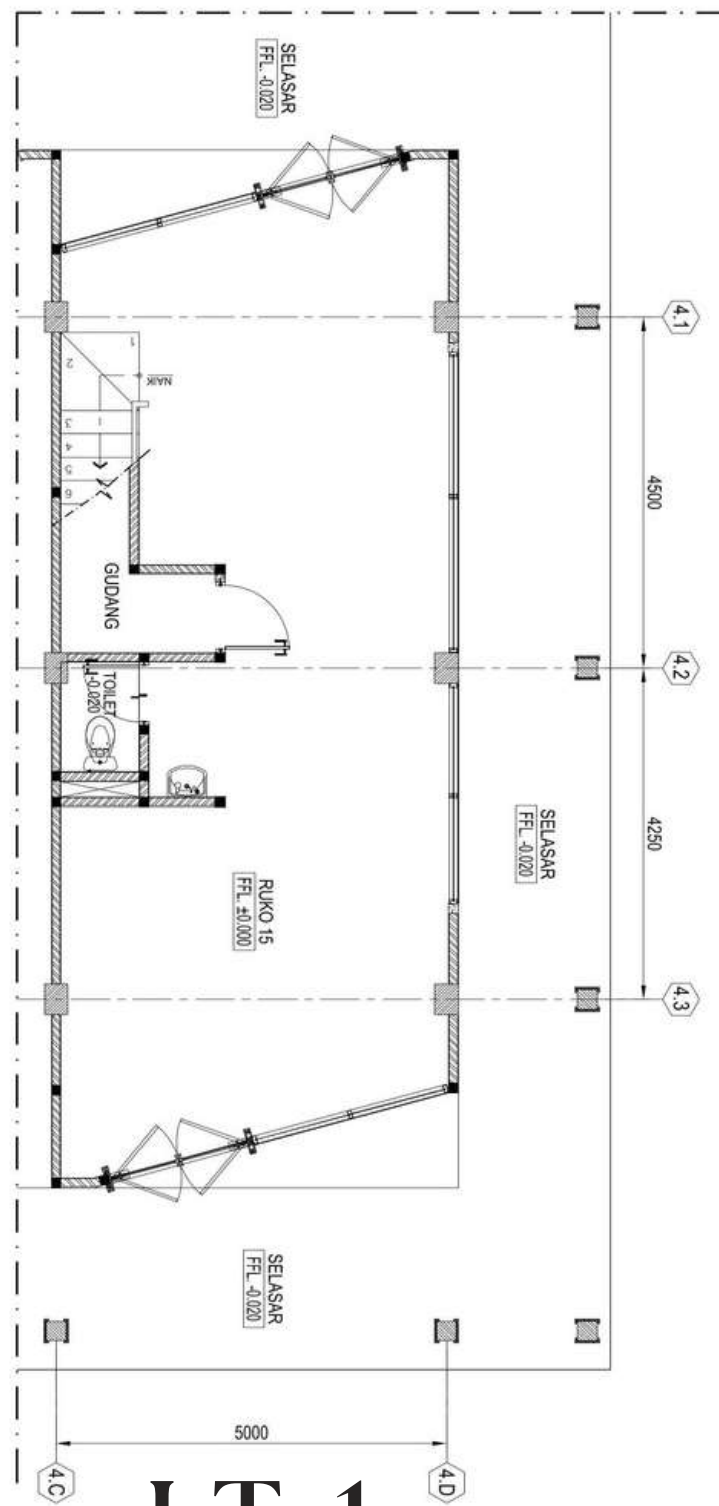

LT.1

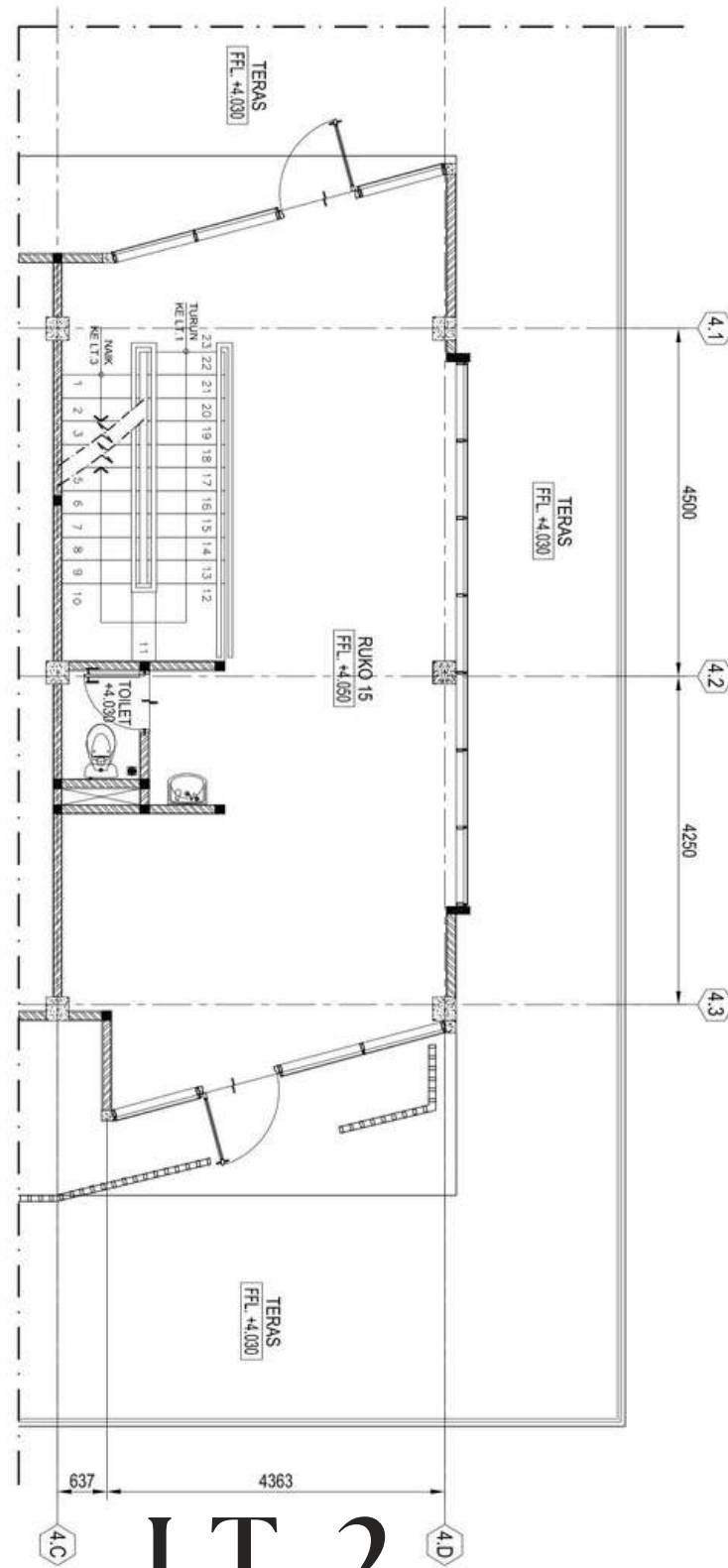

LT.2

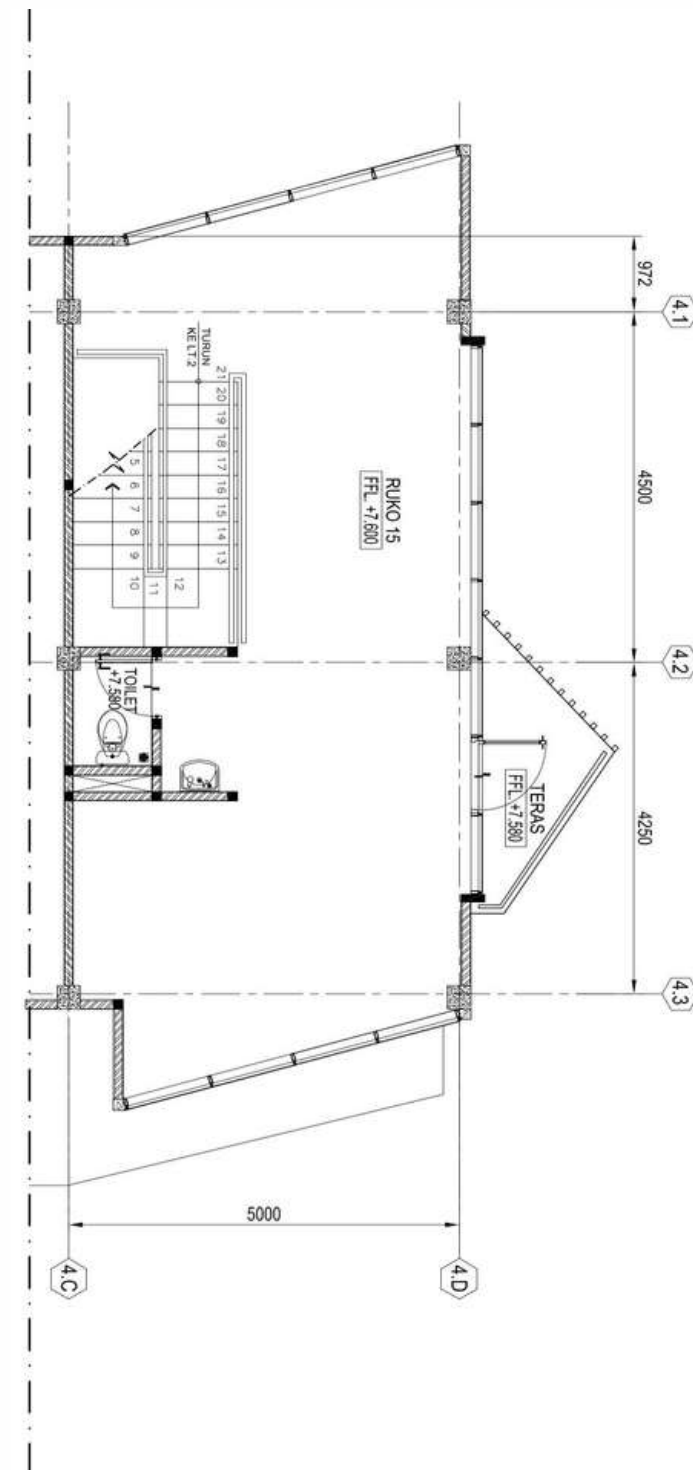

LT.3

RUKO C

LUAS BANGUNAN

• 190m²

• 234 m²

• 255 m²

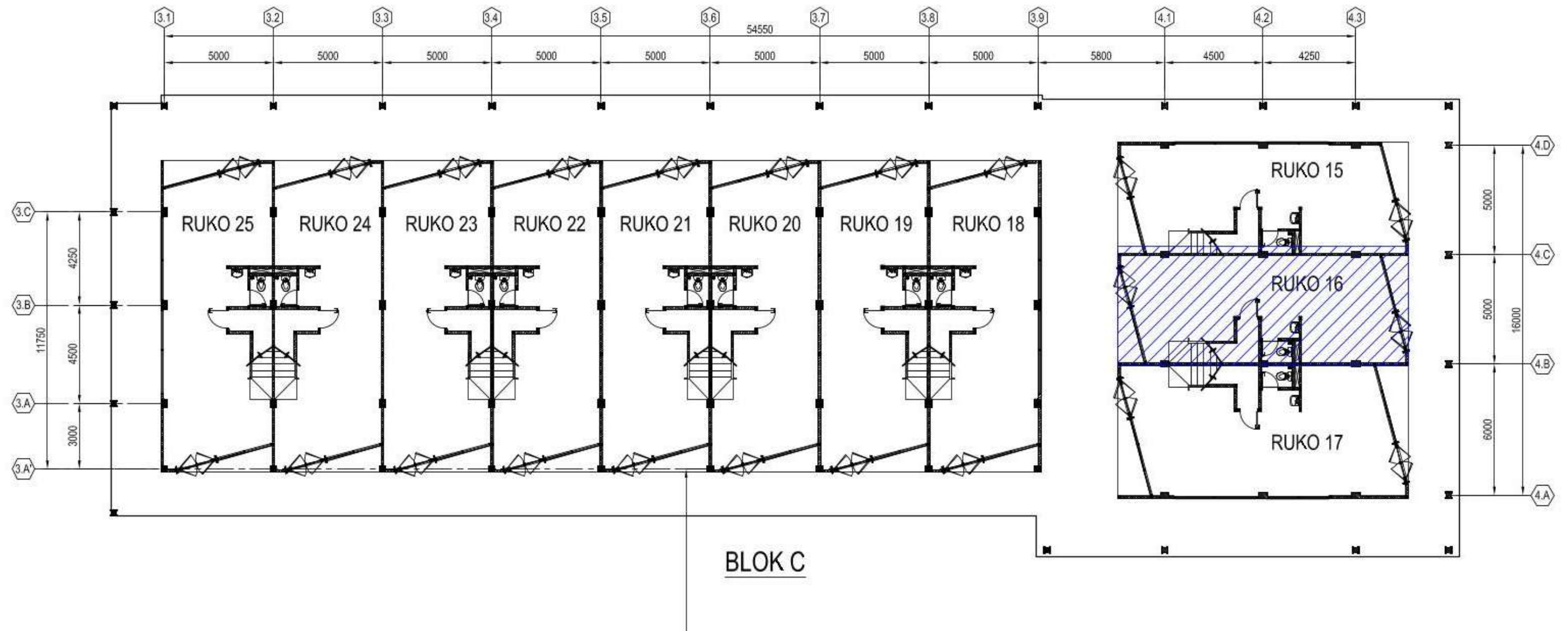

RUKO C

LUAS BANGUNAN

• 190m²

• 234 m²

• 255 m²

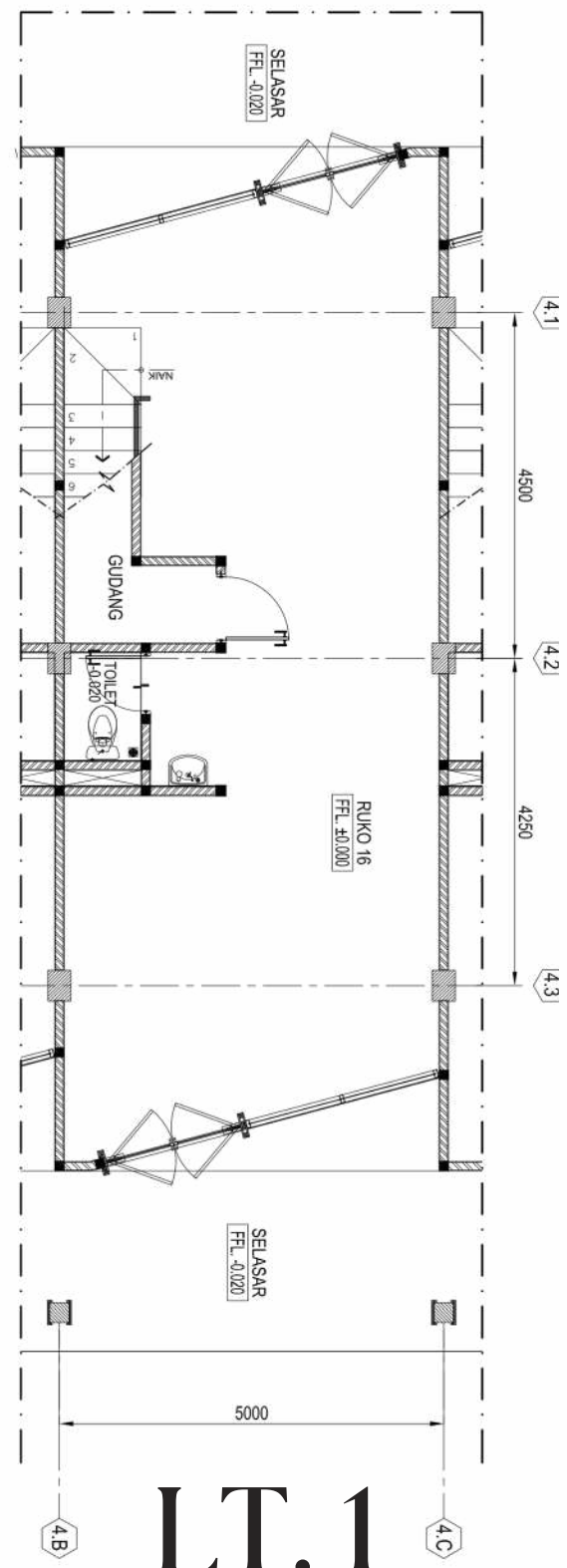

LT.1

LUAS BANGUNAN

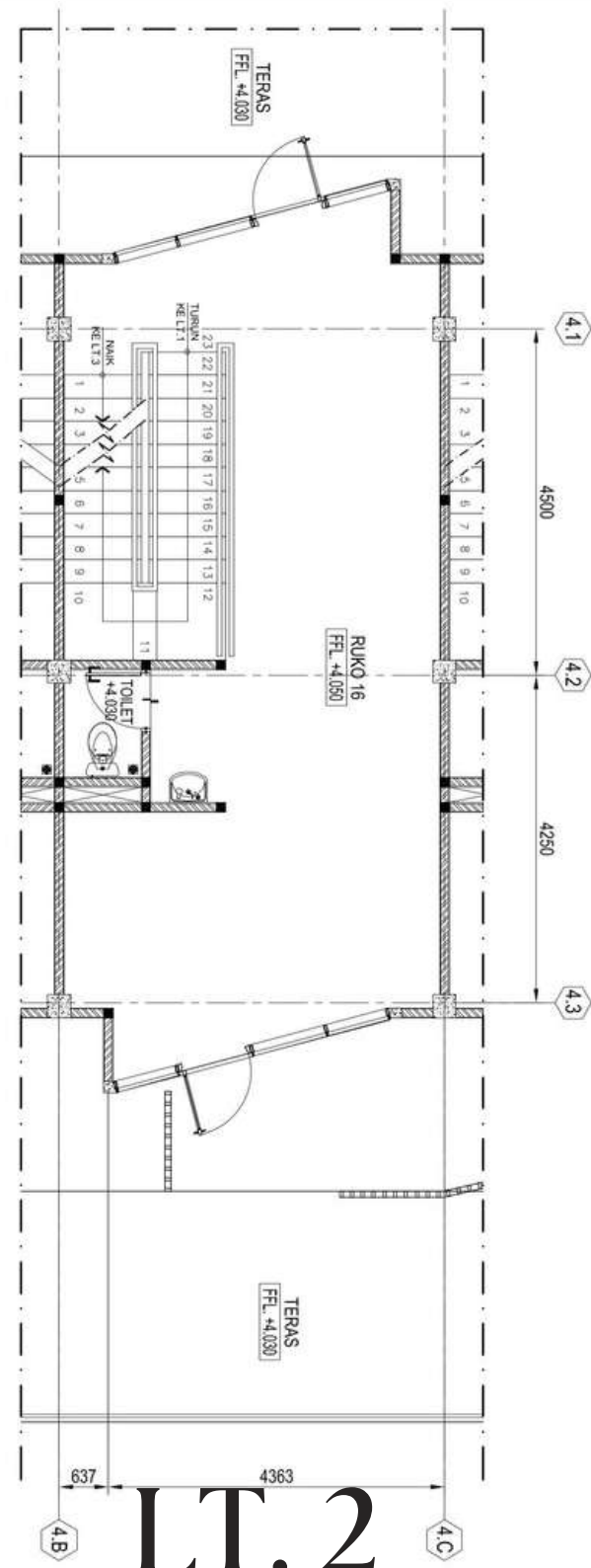

LT.2

RUKO C

• 190m²

• 234 m²

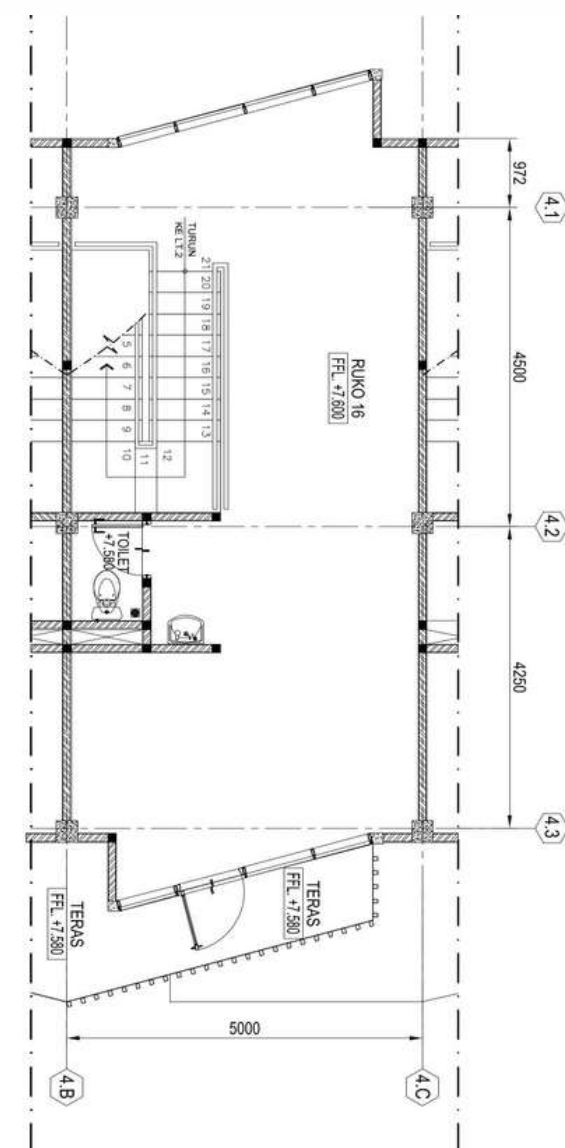

LT.3

• 255 m²

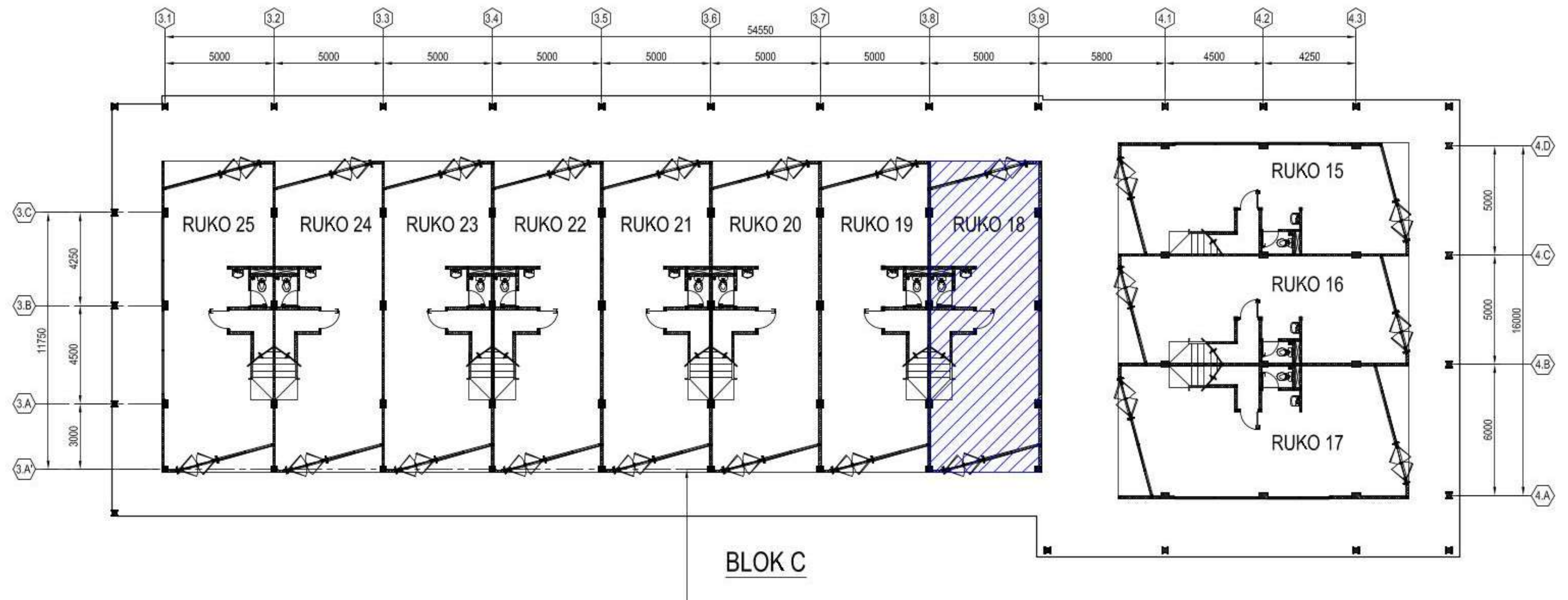

RUKO C

LUAS BANGUNAN

• 190m²

• 234 m²

• 255 m²

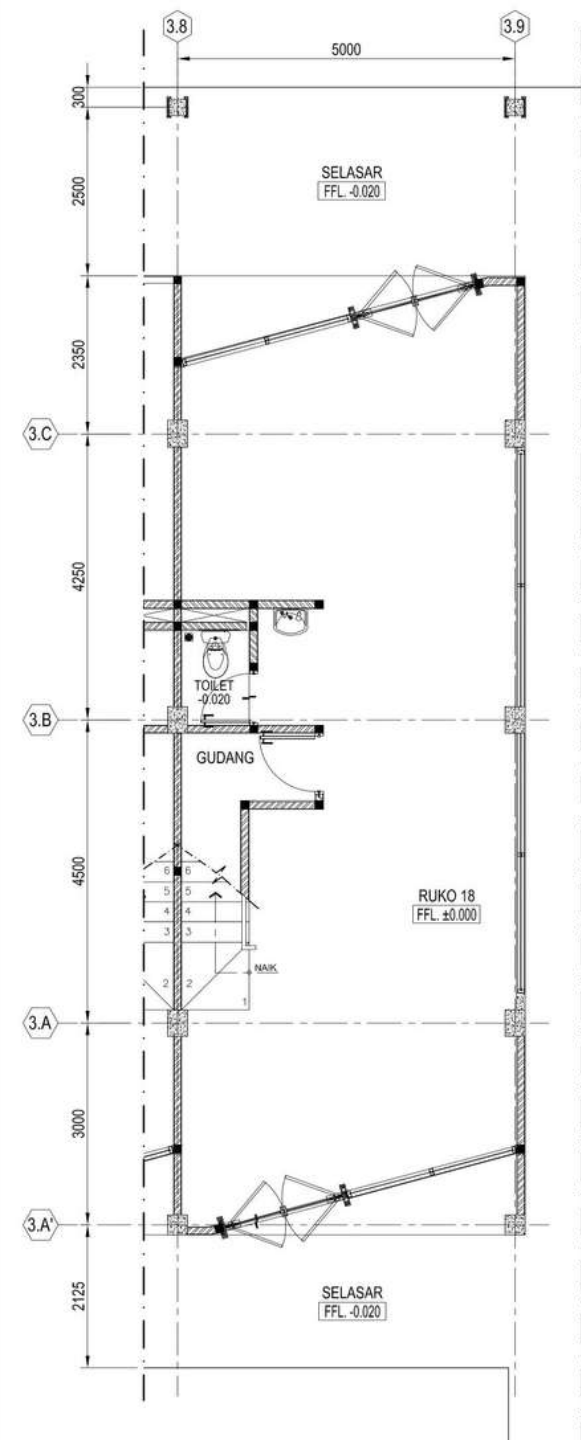

LT.1

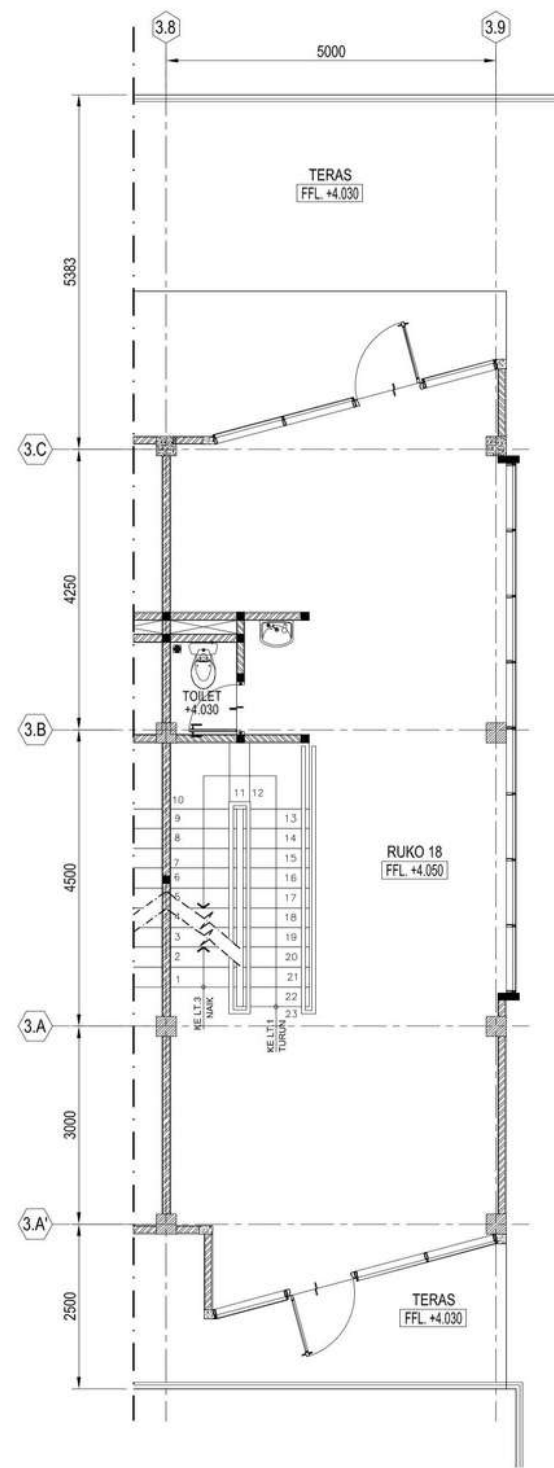

LT.2

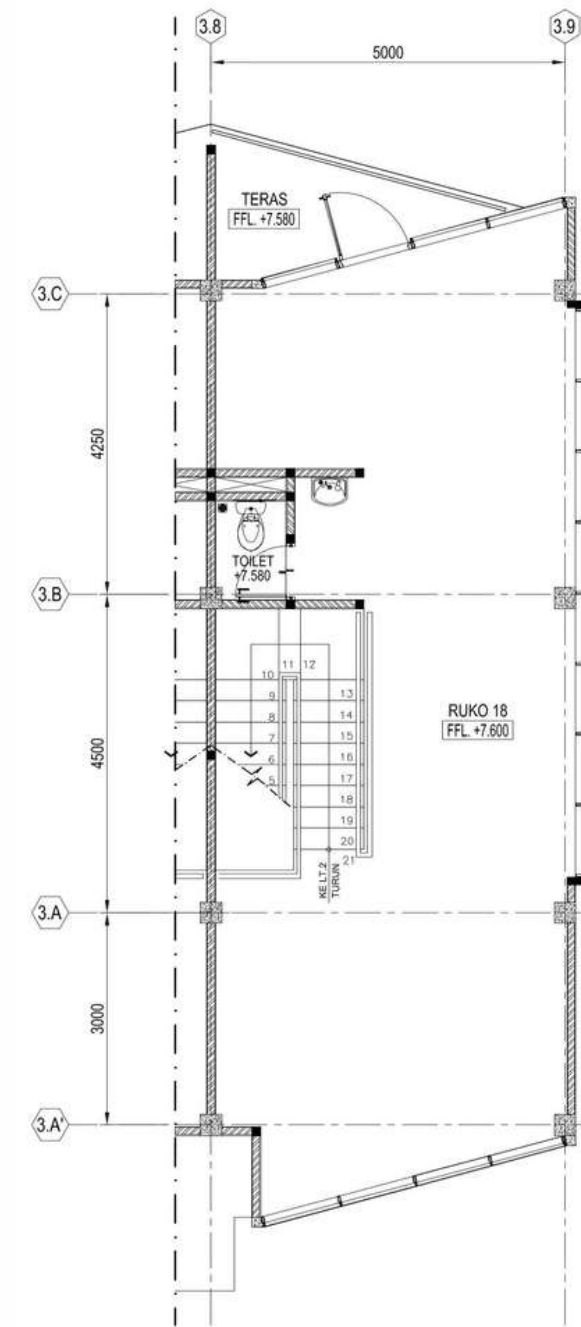

LT.3

RUKO C

LUAS BANGUNAN

• 190m²

• 234 m²

• 255 m²

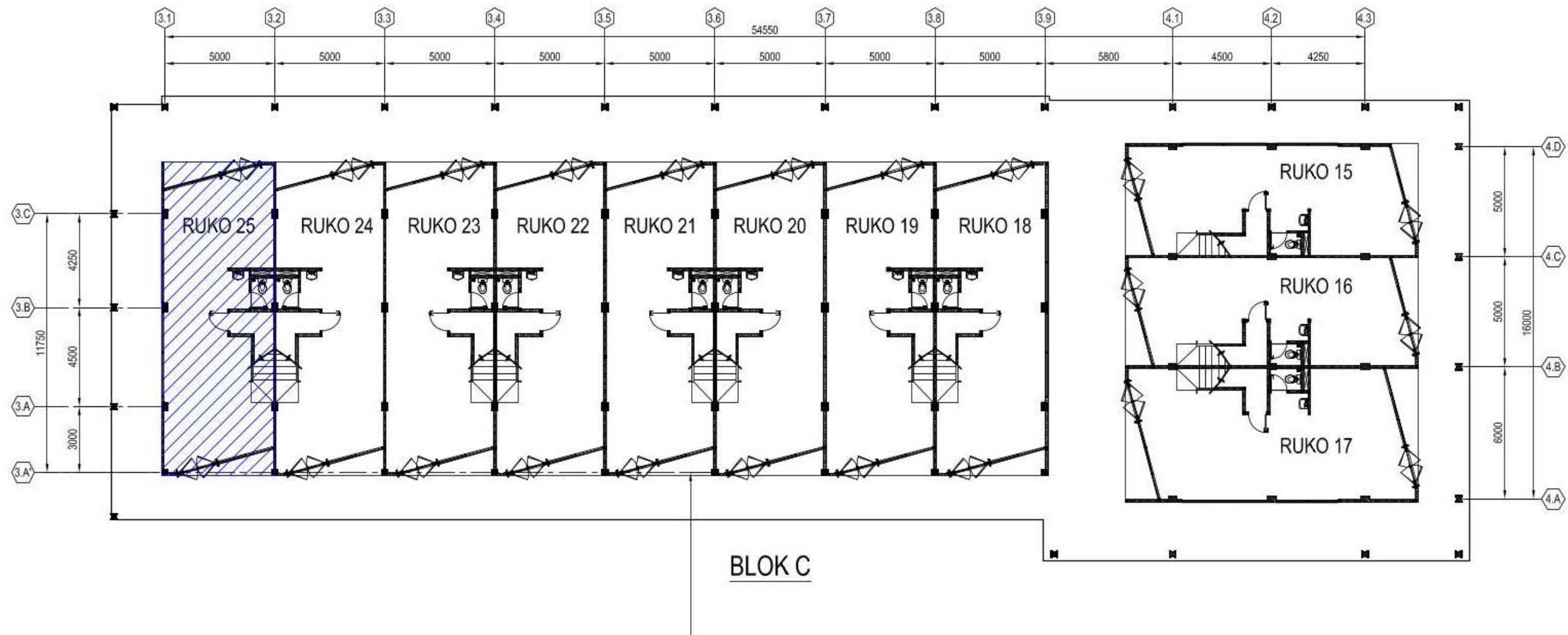

RUKO C

LUAS BANGUNAN

• 190m²

• 234 m²

• 255 m²

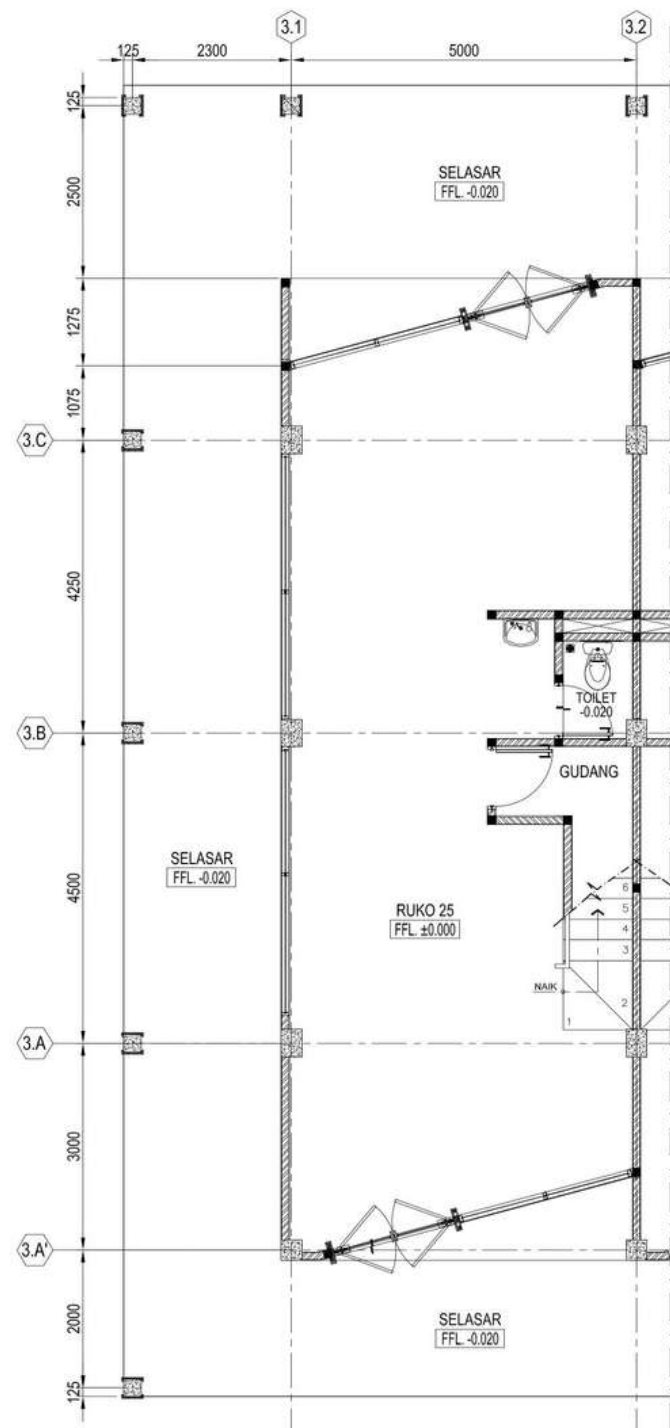

LT.1

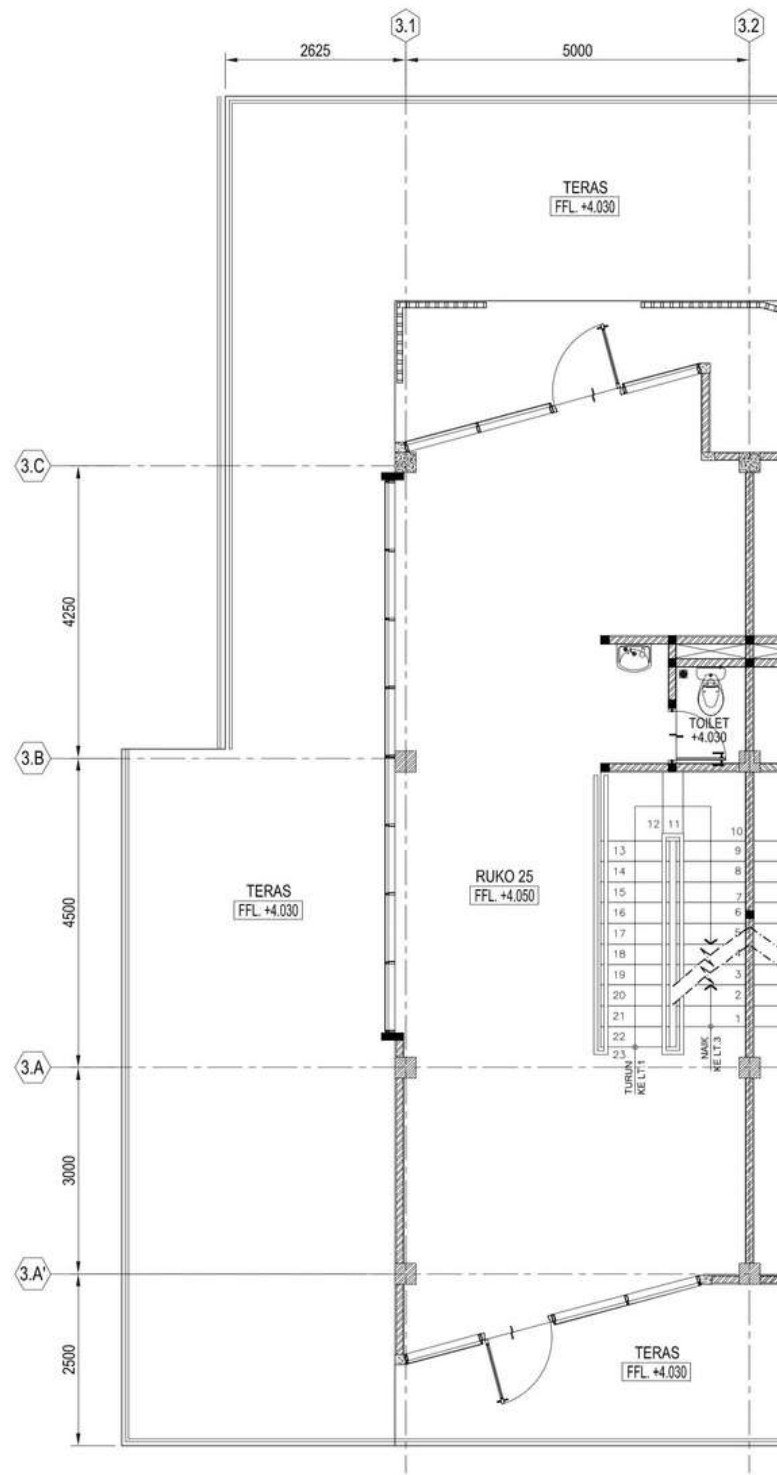

LT.2

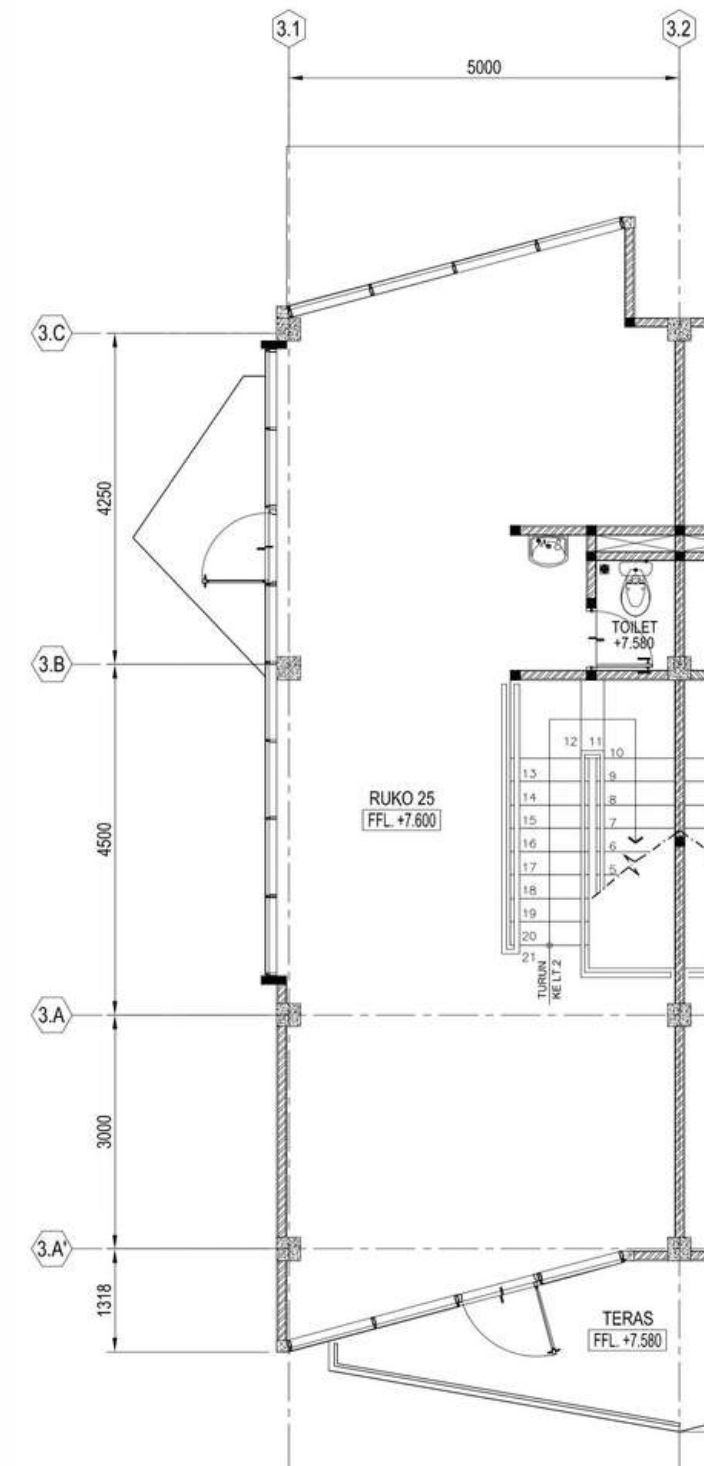

LT.3

RUKO C

LUAS BANGUNAN

• 190m²

• 234 m²

• 255 m²

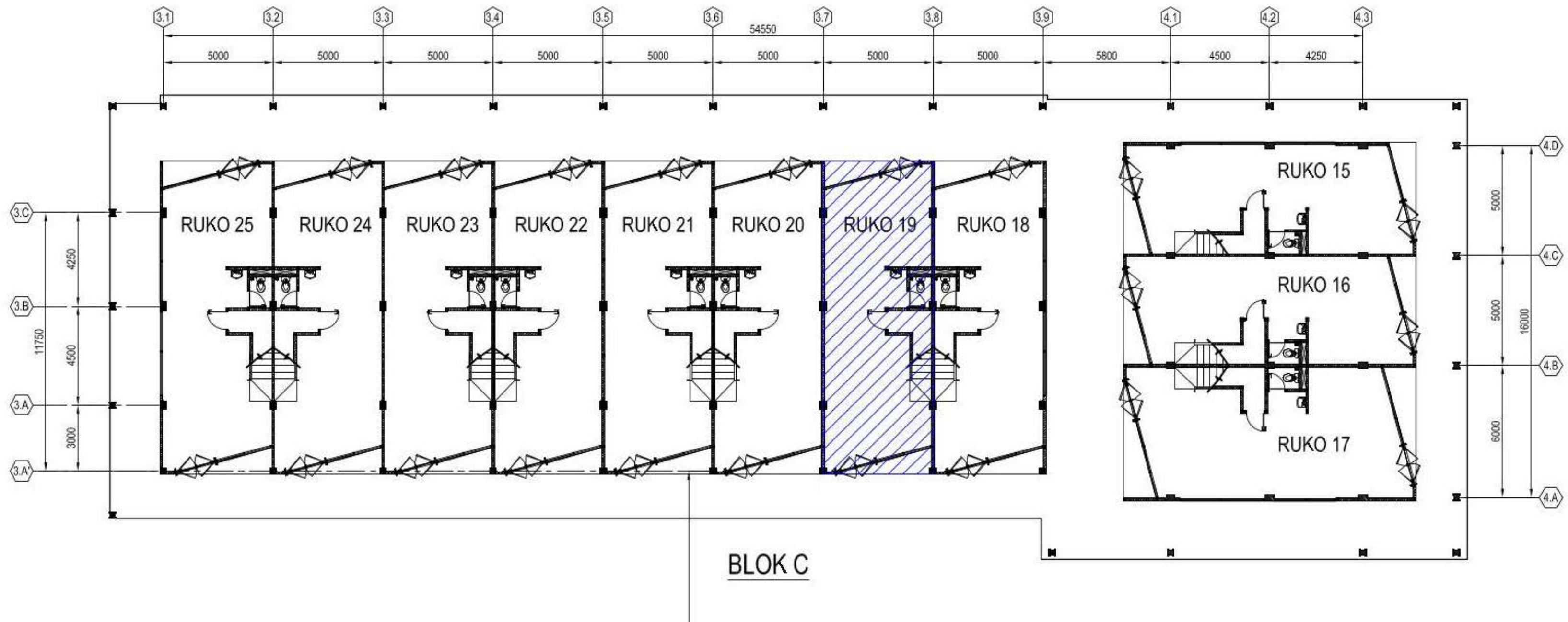

RUKO C

LUAS BANGUNAN

• 190m²

• 234 m²

• 255 m²

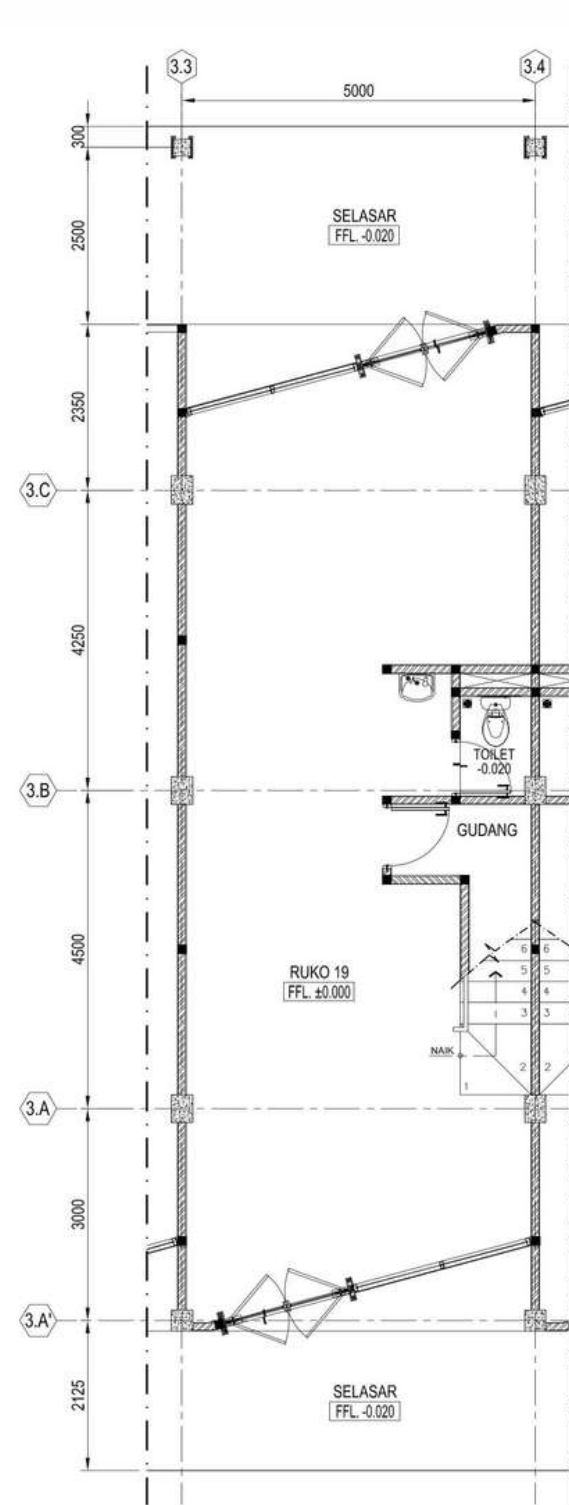

LT.1

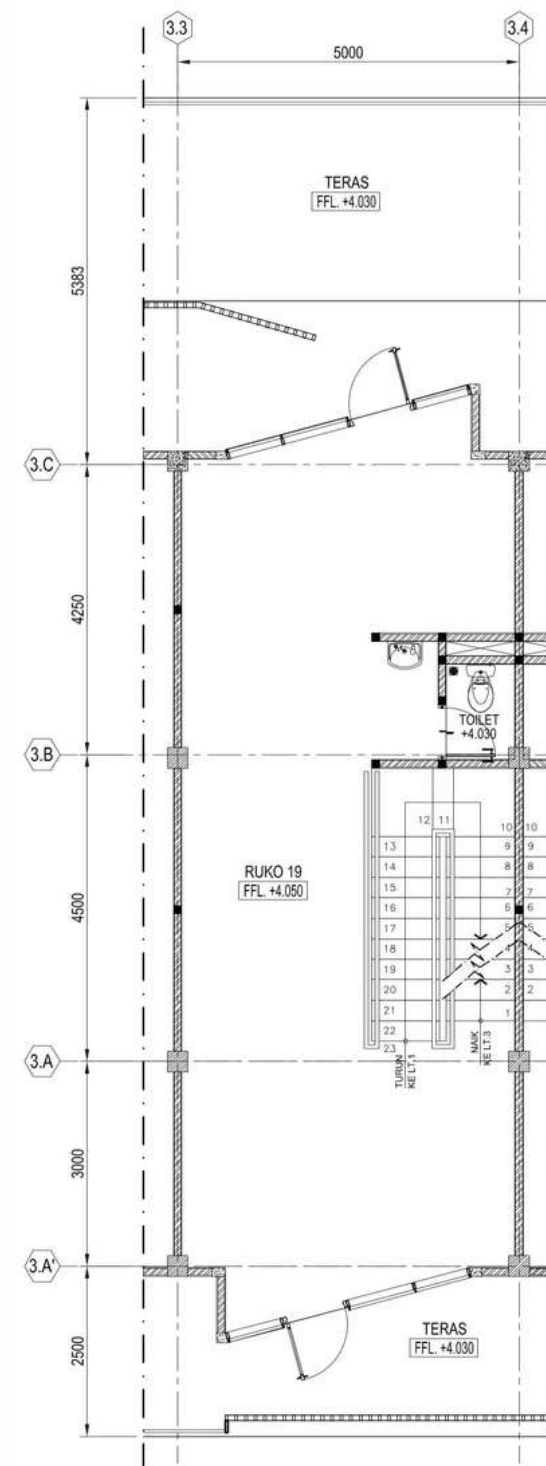

LT.2

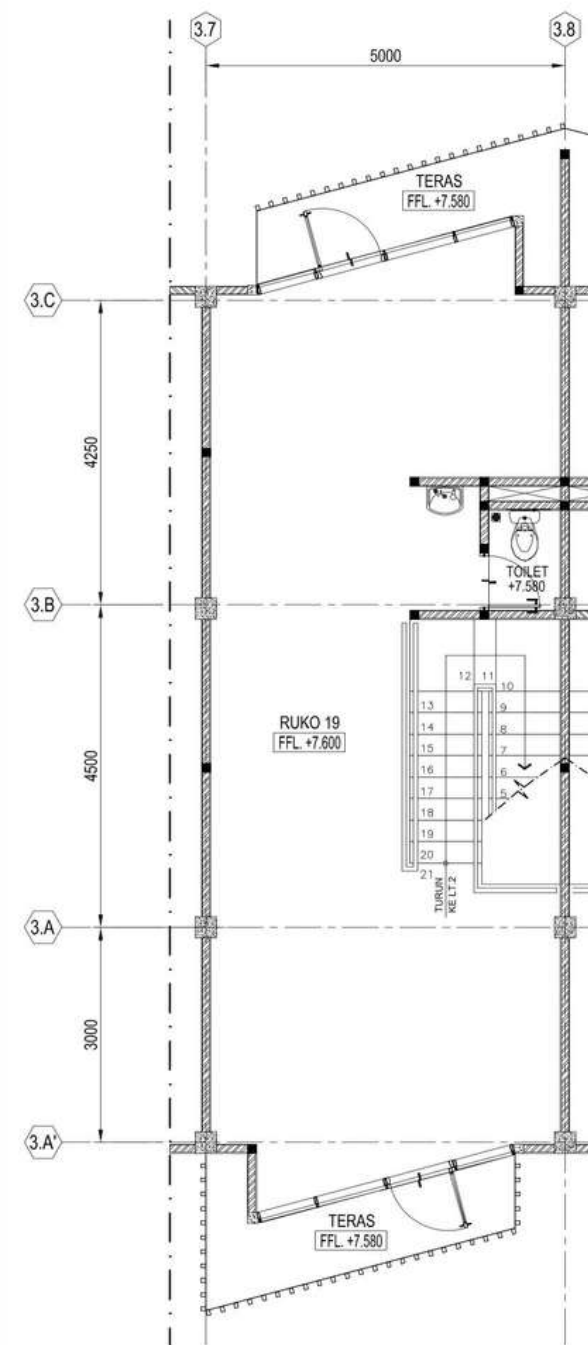

LT.3

RUKO C

LUAS BANGUNAN

• 190m²

• 234 m²

• 255 m²



FACILITY

Memiliki tiga lantai menghadirkan sebuah pengalaman bisnis yang luar biasa dengan fasilitas dan interior yang tak tertandingi.

Kami telah berkomitmen untuk memberikan ruang yang penuh dengan kenyamanan dan kemewahan bagi para pebisnis yang berkomitmen untuk kesuksesan mereka.

Setiap lantai ruko kami telah dilengkapi dengan fasilitas-fasilitas modern yang memudahkan operasional bisnis Anda. Kamar mandi yang bersih dan terawat dengan baik, serta aksesibilitas yang baik dan parkir yang cukup membuat kunjungan ke ruko kami menjadi sangat mudah dan nyaman.

Royal Sentul Park

ROYAL SENTUL PARK



Entrance

ROYAL SENI



24 Hour
Security

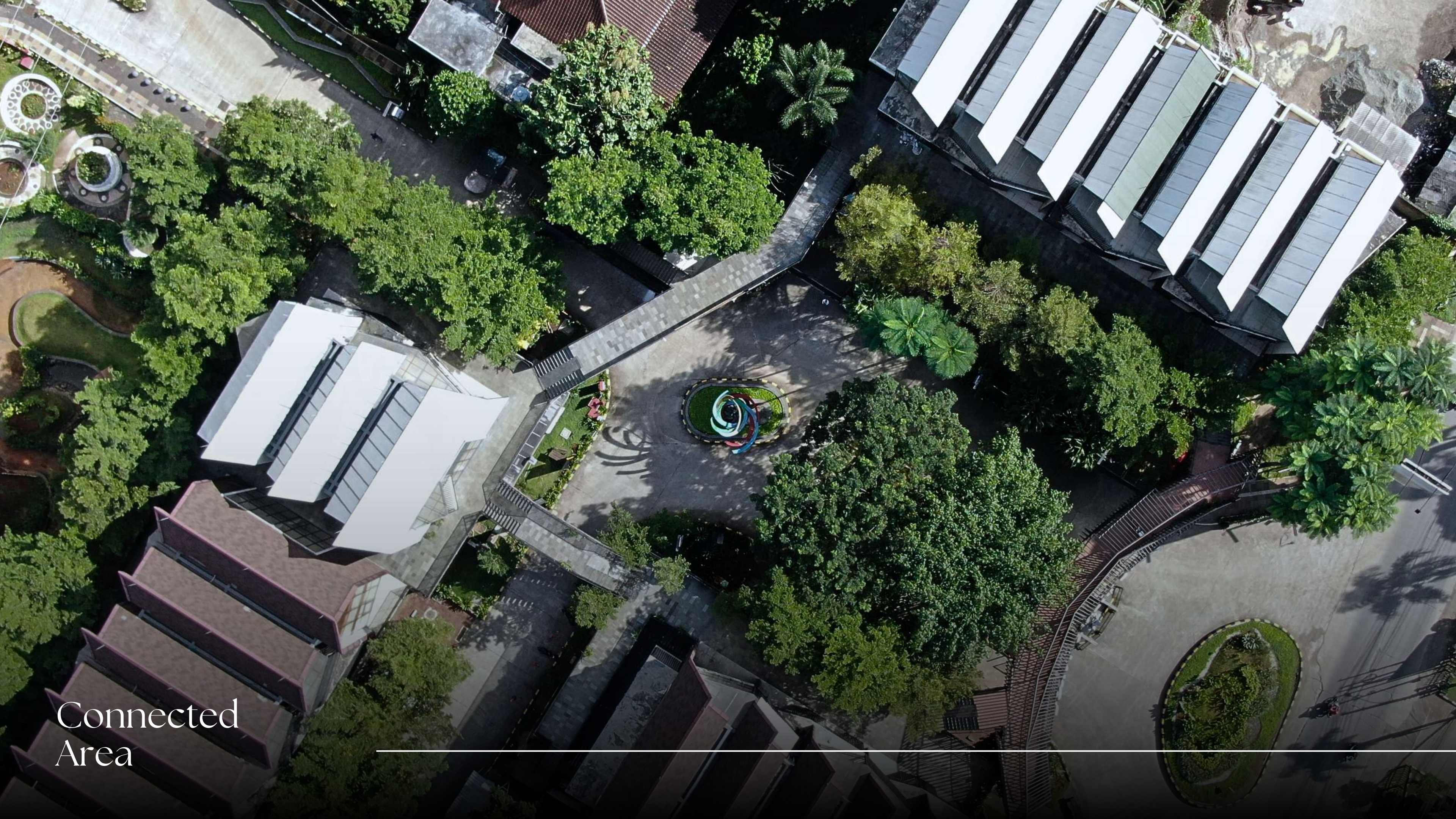

Connected
Area



Immense
Outdoor Space



Jani Jiwa **Jiwa**
toast

LEAF CITY
COMMERCIAL
SOON
LET RAMPAGE
OPERATION 2023
021 8267 1111
0278 8267 1111

WISATA &
KAWAN TANGKAP
KAWAN TANGKAP

JLID 1053

Spacious
Parking Space

AMPITHEATHER



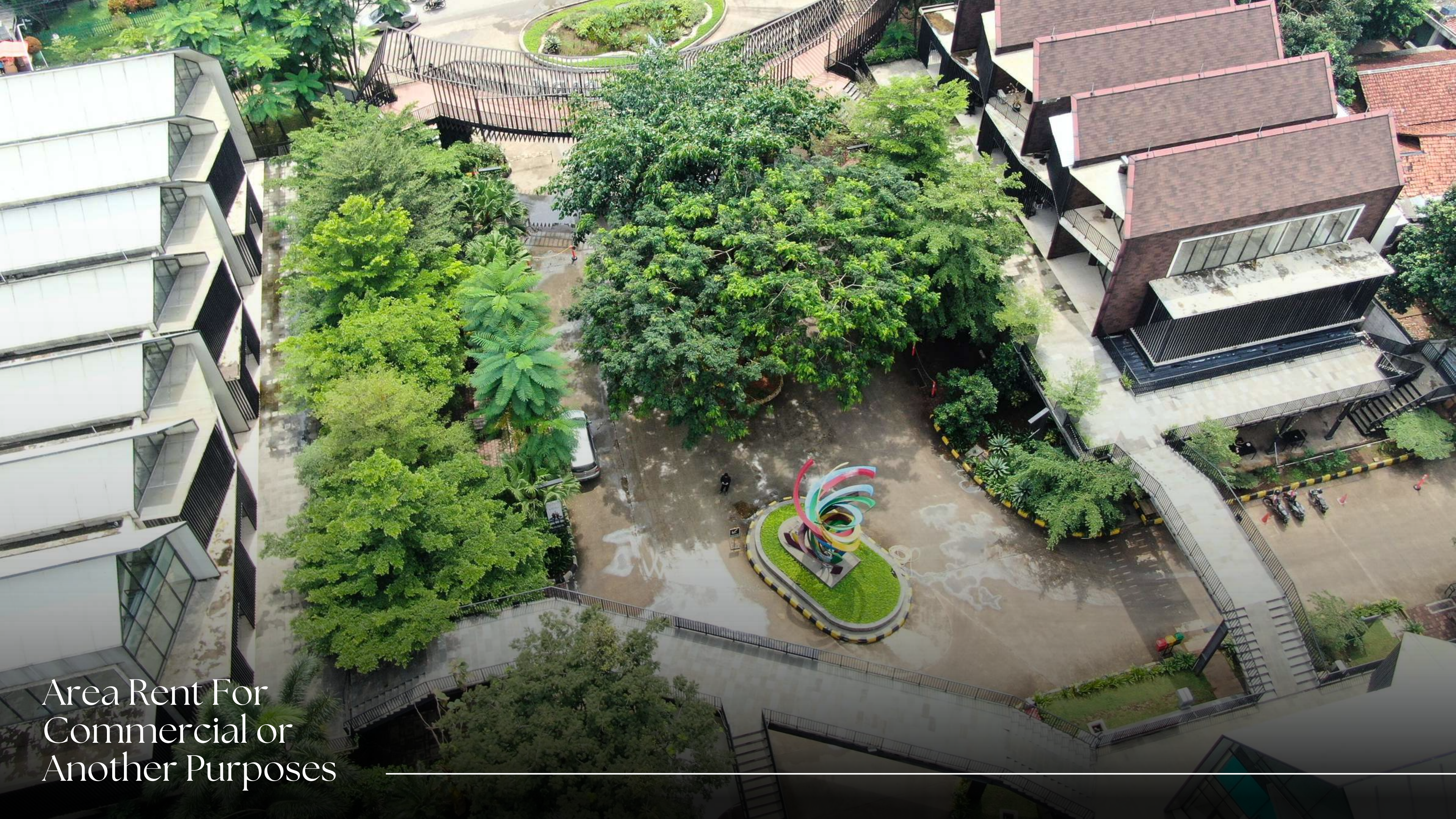

Area Rent For
Commercial or
Another Purposes

RUNNING CAPTIVE MARKET + ROUTINE ACTIVITY

Keberadaan sebuah captive market yang sudah aktif dan berjalan. Ini adalah peluang emas bagi para pebisnis yang ingin memulai usaha mereka tanpa harus membangun pelanggan dari awal. Kami bangga menjadi bagian dari kawasan yang telah mengakar dalam bisnis lokal dan memiliki jaringan pelanggan yang mapan.

C25	AVAILABLE
C24	SOLD
C23	SOLD
C22	AVAILABLE
C21	AVAILABLE
C20	SOLD
C19	AVAILABLE
C18	AVAILABLE

C17	SOLD
C16	SOLD
C15	SOLD

SUNDA YUK!
SUNDANESE RESTAURANT

JANJI JIWA & TOAST
Lt.1



PT. TRUSSCO
Lt.1

A06	SOLD
A05	SOLD
A04	SOLD
A03	SOLD
A02	AVAILABLE
A01	AVAILABLE

B07	SOLD
B08	AVAILABLE
B09	AVAILABLE
B10	AVAILABLE
B11	AVAILABLE
B12	AVAILABLE
B14	AVAILABLE

JANJI JIWA





Coffee & Toast

Sunda Yuk!







Sundanese
Restaurant



Coworking Space

Komitmen de
menunjukkan
keselarasan, m
perbuatan, m
mempertaha
perilaku bisn
etis, mempun
kepemilikan
kuat pada
perusahaan,
menjadi insp
lingkungan s

RITY



Capsule Hotel

ASIOP TRAINING GROUND





Football Training Ground
dengan FIFA Standarisasi



Wedding



Bazaar



Sports



Video Shoot



Hobby



Community Gathering

— Routine Activity —



Kids Football Training
Program dengan ASIOP
Training Ground

ELARTE Football Camp

Family and Kids Activity





Sports

Fun Morning Bike Ride



Sports

Aerobic



Community Gathering

Scooter Gathering



Community Gathering

Pet Days Out



Video Shoot

TV Program



Wedding
Ceremony
Putri & Ridwan



BENEFIT BERGABUNG

Benefit Bergabung

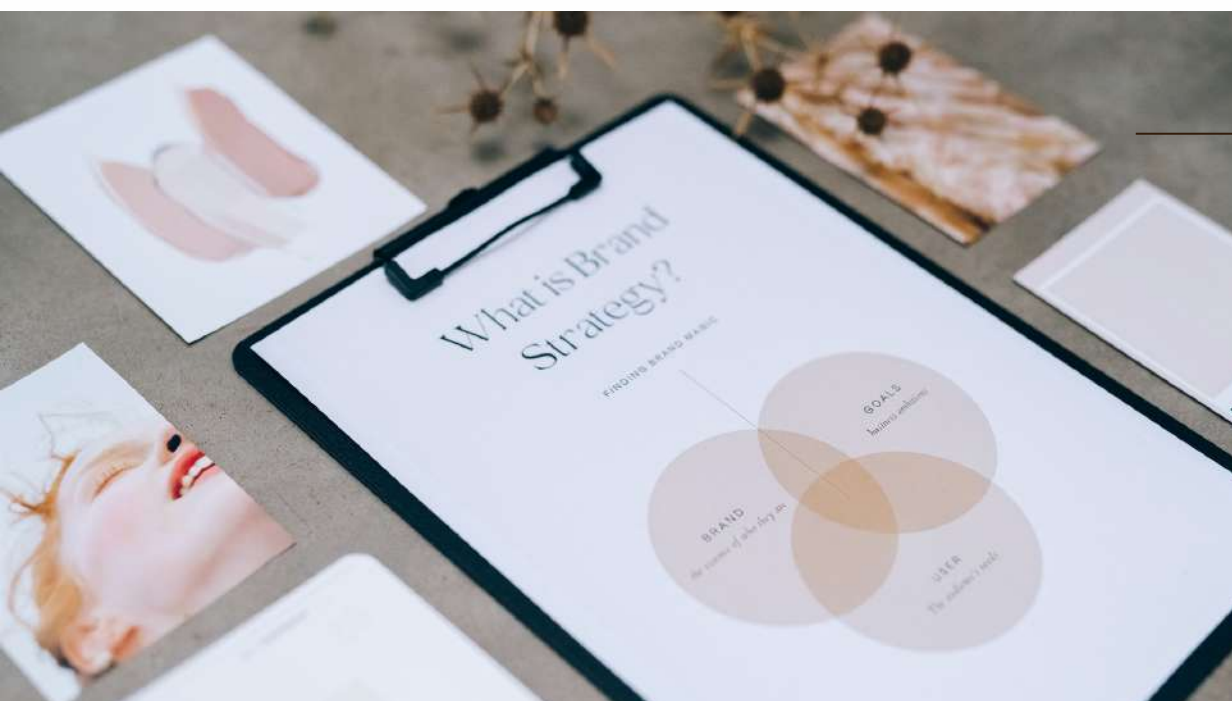

BRANDING

- Konsep Brand
- Brand Identity
- Pemasaran



JOIN PROMOSI

- Promosi Social Media
- Promosi Direct
- Kolaborasi Konten



BEBAS BIAYA PARTISIPASI ACARA RUTIN

Intensitas acara rutin 3-4x
tiap minggu



Taman Budaya



Curug Hordeng



JungleLand Theme Park

— Atraksi Sekitar Kawasan —



Taman Budaya

Jl. Siliwangi No.1, Sumur Batu, Kec. Babakan
Madang, Kabupaten Bogor



Curug Hordeng
Jl. Gunungwangun, Cibadak, Kec.
Sukamakmur, Kabupaten Bogor



Jungleland
Kawasan Sentul Nirwana, Jl. Jungle Land
No.1, Karang Tengah, Kec. Babakan
Madang, Kabupaten Bogor



Mandapa Kirana Resort



Ah Poong



Upper Clift



Gn. Pancar Camping Ground



IKEA

IKEA



Weekenders

And Many More.

Thankyou.

www.lrtcity.com/royal-sentul-park

📷 [Irtcitysentul.id](https://www.instagram.com/lrtcitysentul.id) 📘 [LRT City Sentul](#)

Developed by :



adhi commuter properti

A Subsidiary of PT Adhi Karya (Persero) Tbk.